

TECHNICAL MANUAL
for
RADIO TRANSMITTING SYSTEM
MODEL SYM1205

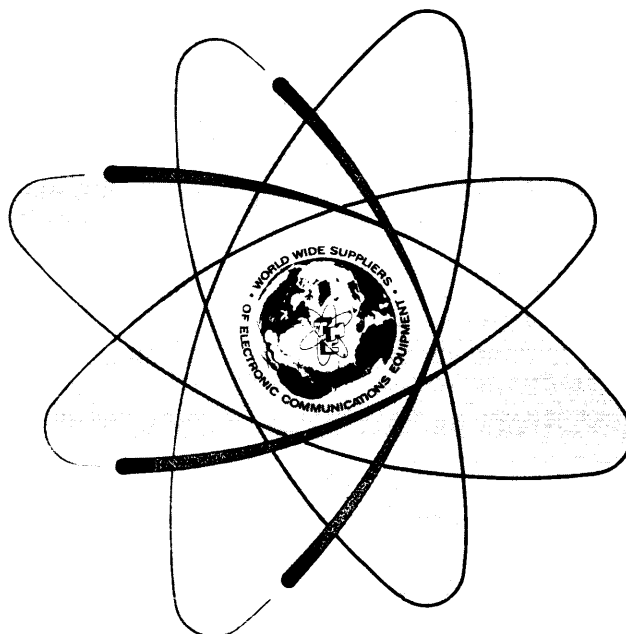

THE TECHNICAL MATERIEL CORPORATION
MAMARONECK, N.Y. OTTAWA, ONTARIO

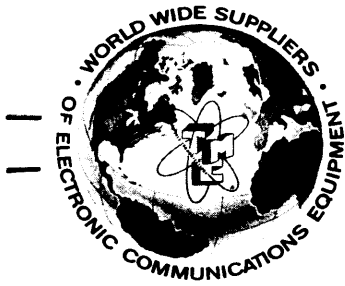

THE TECHNICAL MATERIEL CORPORATION

C O M M U N I C A T I O N S E N G I N E E R S

700 FENIMORE ROAD

MAMARONECK, N. Y.

W a r r a n t y

The Technical Materiel Corporation, hereinafter referred to as TMC, warrants the equipment (except electron tubes,*fuses, lamps, batteries and articles made of glass or other fragile or other expendable materials) purchased hereunder to be free from defect in materials and workmanship under normal use and service, when used for the purposes for which the same is designed, for a period of one year from the date of delivery F.O.B. factory. TMC further warrants that the equipment will perform in a manner equal to or better than published technical specifications as amended by any additions or corrections thereto accompanying the formal equipment offer.

TMC will replace or repair any such defective items, F.O.B. factory, which may fail within the stated warranty period, PROVIDED:

1. That any claim of defect under this warranty is made within sixty (60) days after discovery thereof and that inspection by TMC, if required, indicates the validity of such claim to TMC's satisfaction.
2. That the defect is not the result of damage incurred in shipment from or to the factory.
3. That the equipment has not been altered in any way either as to design or use whether by replacement parts not supplied or approved by TMC, or otherwise.
4. That any equipment or accessories furnished but not manufactured by TMC, or not of TMC design shall be subject only to such adjustments as TMC may obtain from the supplier thereof.

Electron tubes*furnished by TMC, but manufactured by others, bear only the warranty given by such other manufacturers. Electron tube warranty claims should be made directly to the manufacturer of such tubes.

TMC's obligation under this warranty is limited to the repair or replacement of defective parts with the exceptions noted above.

At TMC's option any defective part or equipment which fails within the warranty period shall be returned to TMC's factory for inspection, properly packed with shipping charges prepaid. No parts or equipment shall be returned to TMC, unless a return authorization is issued by TMC.

No warranties, express or implied, other than those specifically set forth herein shall be applicable to any equipment manufactured or furnished by TMC and the foregoing warranty shall constitute the Buyers sole right and remedy. In no event does TMC assume any liability for consequential damages, or for loss, damage or expense directly or indirectly arising from the use of TMC Products, or any inability to use them either separately or in combination with other equipment or materials or from any other cause.

*Electron tubes also include semi-conductor devices.

TABLE OF CONTENTS

<u>Paragraph</u>		<u>Page</u>
<u>SECTION 1 - GENERAL INFORMATION</u>		
1-1	Functional Description	1-1
1-2	Equipment Description	1-1
1-3	Reference Data	1-3
<u>SECTION 2 - INSTALLATION</u>		
2-1	Initial Unpacking and Inspection	2-1
2-2	Power Requirements	2-1
2-3	Installation	2-1
<u>SECTION 3 - OPERATOR'S SECTION</u>		
3-1	General	3-1
3-2	Operating Controls	3-1
3-3	Starting Control Settings	3-1
3-4	Operating Procedure	3-1
<u>SECTION 4 - MAINTENANCE AND TROUBLESHOOTING</u>		
4-1	Preventive Maintenance	4-1
4-2	Alignment	4-1
4-3	Corrective Maintenance	4-1
4-4	Troubleshooting	4-2
<u>SECTION 5 - PARTS LIST SECTION</u>		
	Parts List	5-1

LIST OF ILLUSTRATIONS

<u>Figure</u>		<u>Page</u>
1-1	Radio Transmitting System SYM1205	1-0
2-1	Outline Dimensional Drawing	2-6
2-2	Typical Installation SYM1205	2-7
2-3	System Wiring Diagram	2-8
4-1	System Functional Block Diagram	4-5

LIST OF TABLES

<u>Table</u>		<u>Page</u>
1-1	Transmitter Transmission Modes	1-1
1-2	Technical Specifications	1-3
1-3	Transmitter Power Tube Complement.	1-4
2-1	Interface Connections	2-2
3-1	Starting Control Settings	3-1
3-2	Transmitter Operating Procedure (with GPE-1A).	3-2
3-3	Transmitter Operating Procedure (with SME-5)	3-5
3-4	Transmitter Output Indications	3-5
3-5	Typical Transmitter Tuning Chart	3-6
4-1	Troubleshooting Table	4-1

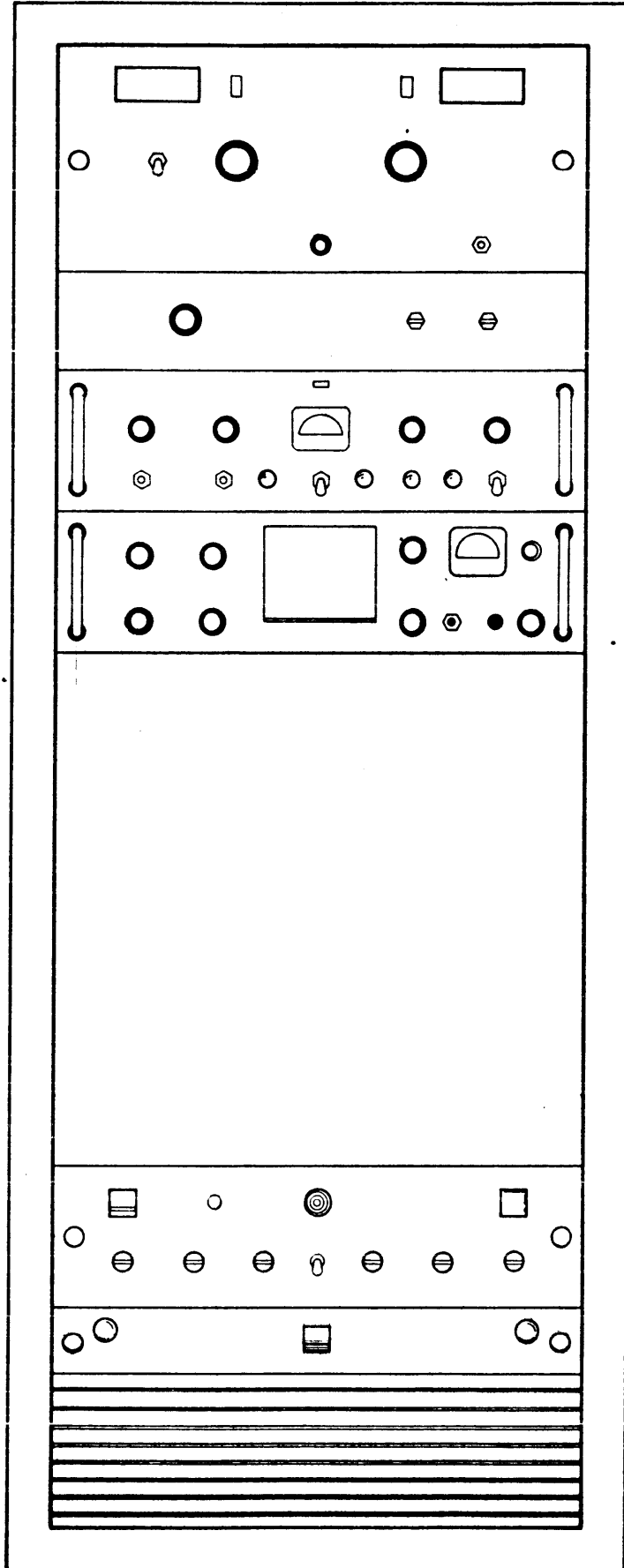

Figure 1-1 Radio Transmitting System
Model SYM1205

SECTION 1

GENERAL INFORMATION

1-1. FUNCTIONAL DESCRIPTION

This manual presents instructions for Radio Transmitting System Model SYM 1205. Included are general description of the equipment, installation and operating procedures. Detailed principles of operation for each modular unit in the transmitter are contained in the applicable modular unit Technical Manuals (HFLM-1K, SME-5, GPE-1A).

Radio Transmitting System, Model SYM 1205 (figure 1-1), hereinafter referred to as system or transmitter consist of the HFLM-1K Linear Power Amplifier used with the GPE-1A and SME-5 exciters.

The HFLM-1K Linear Power Amplifier consist of three basic units (TLAM-1K, AP151, AP152) that amplify the exciters output up to 1 kilowatt in the frequency range of 2-4 MHz. Table 1-1 indicates the type of transmission available with transmitter dual exciter configuration.

The small size and light weight of the transmitter makes it suitable for shipboard aircraft or mobile applications. The SYM 1205 may also be used to update an existing linear amplifier. Refer to Table 1-2 for technical specifications and reference data for the transmitter.

TABLE 1-1 TRANSMITTER TRANSMISSION MODES

<u>MODE</u>	<u>CODE</u>
Amplitude Modulation Equivalent (AME)	A3H
Continuous Wave (CW)	A1
Modulated Continuous Wave (MCW)	A2H
Single Sideband (LSB) (USB)	A3J
Independent Sideband (ISB)	A3B
Pilot Carrier	A3A
Frequency Shift Keying (option) (FSK)	A7J
Amplitude Modulation (AM)	A3

1-2. EQUIPMENT DESCRIPTION

a. Equipment Cabinet The equipment cabinet houses all the transmitter components, 28 inches of blank panel space is provided for future equipment use. The cabinet overall dimensions are listed in Table 1-2. Cable access holes are located in the side and bottom of the cabinet for cable entry.

b. Linear Amplifier TLAM-1K The TLAM-1K is slide mounted in the equipment cabinet and serves as the power amplifier for the transmitter. Essentially the TLAM-1K consist of two low level broad band amplifiers and a final power amplifier. Plate currents and power output of the amplifier are monitored in the TLAM-1K front panel mounted plate current and output meter. The Linear Amplifier receives operating and control voltages from the two associated power supplies AP151, AP152.

c. Low Voltage and Bias Supply Drawer AP151 The AP151 is slide-mounted directly above the AP152. It contains the filament and bias transformer, low voltage transformer, and the overload, bias, and PTT relays. Mounted on the front panel are the SCREEN and PLATE circuit breakers, an INTERLOCKS indicator, the high voltage ATARM and its associated switch; a HIGH VOLTAGE indicator and indicator fuses for BLOWER, FILAMENT, LV, BIAS, DC and CONTROL.

d. High Voltage Power Supply AP152 The heavy high voltate power supply components are mounted on a chassis and slide-mounted in the base of the equipment cabinet. The AP152 contains the high voltage transformer, high voltage on relay, and front and rear blower motors. Mounted on the front panel are the MAIN POWER circuit breaker and indicator lamp.

e. General Purpose Exciter GPE-1A The model GPE-1A Exciter is a general purpose exciter which provides AM, CW and MCW excitation in the 2-32 mHz frequency range. The carrier frequency is generated by a crystal controlled oscillator with front panel control selection of three replaceable crystals in the 2-4 mHz range. This exciter provides adjustable power output up to 200 MW and is used as a source of excitation for the SYM 1205 transmitter system.

f. Sideband Multi-Channel Exciter SME-5 The SME-5 is the second exciter in the dual exciter configuration of the SYM 1205 transmitter. This exciter is mounted directly above the GPE-1A exciter and serves to provide single sideband (A3J), independent sideband (A3B), modulated continuous wave (A2H), continuous wave (A1), and amplitude modulation equivalent (A3H). The SME-5 provides up to eight channel frequencies in the 2-30 mHz frequency range. Operating frequency selection is accomplished by setting a single front panel mounted channel select switch to the desired channel frequency. The SME-5 will accept audio inputs from two 600 ohm lines, a carbon or dynamic microphone and a CW key. Two independent audio inputs may be provided for simultaneous transmissions. The exciter provides up to 100 MW excitation for the HFLM-1K Linear Amplifier.

g. Exciter RF Output Control AX5145 RF Output Control panel is mounted directly above the SME-5 Exciter. The AX5145 is equipped with an RF OUTPUT switch and two test keys (one for each exciter). The RF OUTPUT switch routes the output of either exciter to the input of the Linear Amplifier. This provides exciter selection. The test keys provide front panel key down for testing and tuning purposes when placed in the "up" (locked) position.

1-3. REFERENCE DATA

Table 1-2 list the Technical Specifications of the SYM 1205 transmitter and Table 1-3 list the transmitter power tube complement.

TABLE 1-2. TECHNICAL SPECIFICATIONS

Frequency Information

Range	2 to 30 MHz is Standard; 1.5 to 30 MHz is Optional.
Stability Synthesized	One part in 10^6 per day.

Operational

Modes	CW(A1), AM(A3), AME(A3H), USB(A3A), LSB, two-channel ISB(A3B).
Carrier Suppression	Continuously adjustable throughout the range of -50db on AME and Pilot Carrier.
Power Output	1000 watts PEP and AVERAGE (CW) continuous, key-down service.
Output Impedance	50 ohms nominal unbalanced; 70 ohms nominal Optional.
VSWR	Maximum of 2:1 without degrading performance.
ALDC	Automatic Load and Drive Control to improve linearity, limit distortion, and maintain relatively constant output level during high modulation peaks and load changes. Front panel control allows adjustment of the level at which the ALDC takes effect.

Power Distortion and Noise Ratings

Spurious Signals	At least 50 db down from full PEP output.
Noise Level	At least 50 db down from full PEP output.
Intermodulation	Distortion products are at least 35 db below either tone of a standard two-tone test at full rated PEP.

Audio

Sideband Response	± 1.5 db, ± 350 3300Hz (GPE-1A) ± 1.5 db, ± 300 -3000Hz (SME-5)
-------------------	--

TABLE 1-2. TECHNICAL SPECIFICATIONS (cont)

Audio

- Input
- 1) Two independent 600 ohm channels, balanced or unbalanced.
 - 2) Microphone Selection for high and low level dynamic microphone. Front panel selection and jack.

Keying Information

CW Key jack on front panel and terminals on rear apron.

Installation and Environmental Data

Environmental Operates 0 to +50°C with up to 90% relative humidity.

Cooling High capacity, filtered, forced air.

Primary Power 115/230VAC, 50/60Hz, Single Phase

Size 73-7/8 inches high x 23 inches wide x 26 inches deep.

Weight approximately 500 pounds.

TABLE 1-3. TRANSMITTER POWER TUBE COMPLEMENT

<u>Reference Designation</u>	<u>Part Number or type</u>	<u>Function</u>
V1201	8233	1st RF Amplifier
V1202	4CX350A	2nd RF Amplifier
V1301	8576	Power Amplifier

SECTION 2

INSTALLATION

2-1. INITIAL UNPACKING AND INSPECTION

The SYM 1205 transmitter was assembled, calibrated and tested at the factory before shipment. Inspect all packages for possible damage during transit. With respect to damage to the equipment for which the carrier is liable, The Technical Materiel Corporation will assist in describing methods of repair and furnishing of replacement parts. Carefully unpack each crate as indicated by the packing list provided with the transmitter shipment. Inspect all packing materials for parts that have been shipped as LOOSE ITEMS (cabinet hardware, connector, technical manuals, etc.).

2-2. POWER REQUIREMENTS

The transmitter requires a single phase source of 115/230 vac, 50/60Hz at approximately 3.75 kilowatts. (Transmitter is pre-wired for 115 or 230 vac as specified at the time of order)

2-3. INSTALLATION

a. General A minimum number of assemblies, subassemblies, components and hardware have been disassembled from the equipment and separately packaged, thus reducing the possibility of equipment damage in transit. the method of disassembly and separate packaging also permits realistic equipment handling.

Cables, wire, and other miscellaneous items that are disconnected during equipment disassembly are tagged and taped to the equipment. The information on a given tag indicates the designated terminal on a component to which the tagged item must be connected. Make sure all cables and wires have been connected as designated on tags and that all packing material, tags and taped have been removed before sealing-up the cabinet or section of the cabinet with a front panel drawer.

b. Equipment Cabinet Installation Remove equipment cabinet from crate and position upright (mounting holes and AC Power jack are located on the bottom portion of the equipment cabinet). Mount cabinet in installation location use mounting hardware and mounting holes in bottom of equipment cabinet. The cabinet dimensions are 73-7/8" high x 23" wide x 26" deep. Provide clearance space of at least two feet from the rear of cabinet to allow for door removal and external cable connections. Refer to figure 2-1 for mounting hole dimensions.

c. Component Installation The component location for typical installation of the transmitter is shown in figure 2-2. The following units in the transmitter are slide mounted; all components of the HFLM-1K (TLAM-1K, AP151,

AP152), and GPE-1A and SME-5 exciter units. The modular units of the HFLM-1K should be installed into the equipment rack by referring to the detailed installation procedural steps in the technical manual for the HFLM-1K. The exciter units GPE-1A and SME-5 should be installed in the equipment rack in the same manner as the HFLM-1K modular units; the front panel of the exciter units should be fastened to the rack with four screws and four washers.

WARNING

BEFORE MAKING EXTERNAL CONNECTIONS TO THE TRANSMITTER, INSURE THAT THE EXTERNAL PRIMARY POWER IS OFF AND TAGGED.

d. Electrical Interconnections Once the modular units (AP151, AP152, GPE-1A, SME-5 and TLAM-1K) have been mounted into the transmitter equipment cabinet, refer to interconnect wiring diagram and connect all plugs to their respective jacks. All interconnecting cables are marked with their "J" numbers and mating "P" numbers at the plug for ease of installation.

e. Interface Panel Connections External input connections to the transmitter are made at the Interface Panel located in the rear of the transmitter below the GPE-1A Exciter Unit. The Interface panel consist of six barrier terminal boards TB1 thru TB6 that provide a termination point for intelligence. inputs, external transmitter control and transmitter status indication. The transmitter Interface Panel is equipped with jumper connections between terminal boards TB2, TB3, TB4 and TB6, these jumper connections complete circuits within the transmitter to enable operation and should only be removed when external lines are used. Refer to wiring diagram and observe note on sheet 2 for information regarding transmitter control jumpers and or external lines in lieu of jumped out connections.

Table 2-1 indicates the function of each terminal board connection on the Interface Panel.

TABLE 2-1. INTERFACE CONNECTIONS

<u>Terminal Number</u>	<u>Function</u>
(1) (2) (3)	600 ohm Audio input to Line 2
(5) (6) (7)	600 Ohm Audio input to Line 2
(8) (9)	Carbon microphone connection
(9) (10)	Dynamic microphone connection

TABLE 2-1. INTERFACE CONNECTIONS (cont)

TB2 SME CONTROL

<u>Terminal Number</u>	<u>Function</u>
(3) (4)	PTT input: input terminals for connection of external PTT device.
(5) (6)	CW Keying: connect keying device.
(7) (8) (9)	XMIT/RCV/COM: xmit terminal (8) provides a ground to xmtr PTT circuit. RCV terminal (7) grounded when xmtr is off.

TB3 XMTR CONTROL

<u>Terminal Number</u>	<u>Function</u>
(1) (2) (3)	External Interlocks
(4) (5)	H.V. on indicator: Connect external indicating device in series with terminal 4 & 5.
(6) (7)	Activates meter relay K101.
(8) (9)	Connect external forward and reflected power meter on terminal 8 & 9 respectively. (Use 0-100 microamp DC meter.)
(10) (11)	H.V. ON: complete circuit via switch, pushbutton.
(12)	+24VDC: 24VDC on terminal 12 when main power breaker is on.

TB4 XMTR CONTROL

<u>Terminal Number</u>	<u>Function</u>
(1)	Xmtr PTT relay coil must be terminated to ground at TB4-2 or connected as per wiring diagram.
(3) (4) (5)	External Overload Reset: connect in-activated or Normally open switch.
(6) (7)	External Overload Indication: indicates an overloaded condition.

TABLE 2-1. INTERFACE CONNECTIONS (cont)

TB4 XMTR CONTROL

<u>Terminal Number</u>	<u>Function</u>
(8) (9)	RECYCLE: for use with transmitters equipped with automatic overload re-cycling unit.
(10) (11) (12)	RCVR MUTE: provides contact closure for RCVR MUTE when XMTR OFF.

TB5 GPE AUDIO

<u>Terminal Number</u>	<u>Function</u>
(1) (2) (3) (4)	600 ohm Audio line connections, use shielded pair.
(5) (6)	Carbon microphone connection.

TB6 GPE CONTROL

<u>Terminal Number</u>	<u>Function</u>
(1) (2)	External PTT connections for GPE-1A.
(3) (4)	External Kyeline Input for GPE exciter.
(5) (6) (7)	Provides transmitter PTT control when connected to TB4-1.

f. RF Output Connection Connect 50 ohm transmission line to RF OUTPUT jack J2002. Transmission line should be terminated into 50 ohm dummy load or antenna. (Connector plug UG495/U is supplied as a loose item for antenna connection.)

This completes the external connections to the Interface Panel. Check that all connections are secure and correctly made, if necessary refer to Wiring Diagram.

g. Primary Power Connections The transmitter leaves the factory wired as per customer requirements for 115 vac or 230 vac operation. Transmitter power requirements are as follows:

1. 115 vac/or 230 vac (on request).
2. Single phase AC at approximately 3.75kw, 50/60 Hz. Connect Power plug to Power Input Jack J2001 located on the bottom portion of the equipment cabinet. (AC connector plug PL190NG is supplied as a loose item for AC input connection.)

NOTE

The equipment cabinet is equipped with two (2) safety interlock switches that must be closed before operating the transmitter. One interlock switch is located on rear wall of equipment cabinet and is closed when rear door is mounted on cabinet. A second interlock switch located on the cabinet wall is closed when AP152 (bottom unit) is mounted into the equipment cabinet and fasten with panel locks.

h. Future Equipment Installation (XFK-2) The equipment cabinet has approximately 28" of panel space for future equipment. Future equipment should be mounted in the equipment and connected to AC strip mounted on rear wall of equipment cabinet. Insure that future equipment is wired for proper line voltage input.

NOTE

When frequency Shift Exciter XFK-2 is used as future equipment, interconnect signal cables as follows:

XFK-2 output jack J1 should be connected to GPE EXT VFO input jack J2 on the Interface Panel. The XFK-2 output frequency must be within the 2-4 MHz range at approximately 1 VRMS.

i. SME-5 IF Input Connections A modulated 1750 kHz may be connected to the EXT SME IF jack (J1) located on the Interface Panel in place of 600 ohm audio on Line 1 and Line 2.

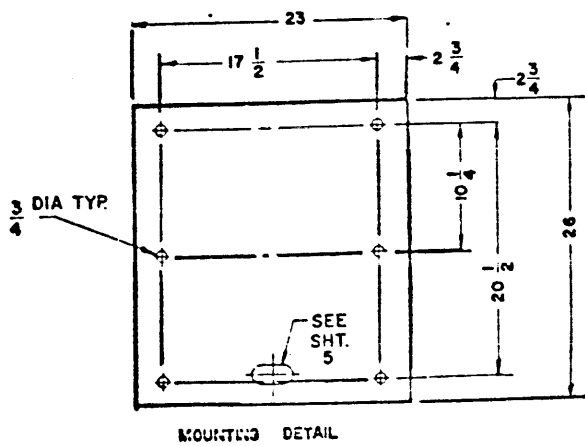
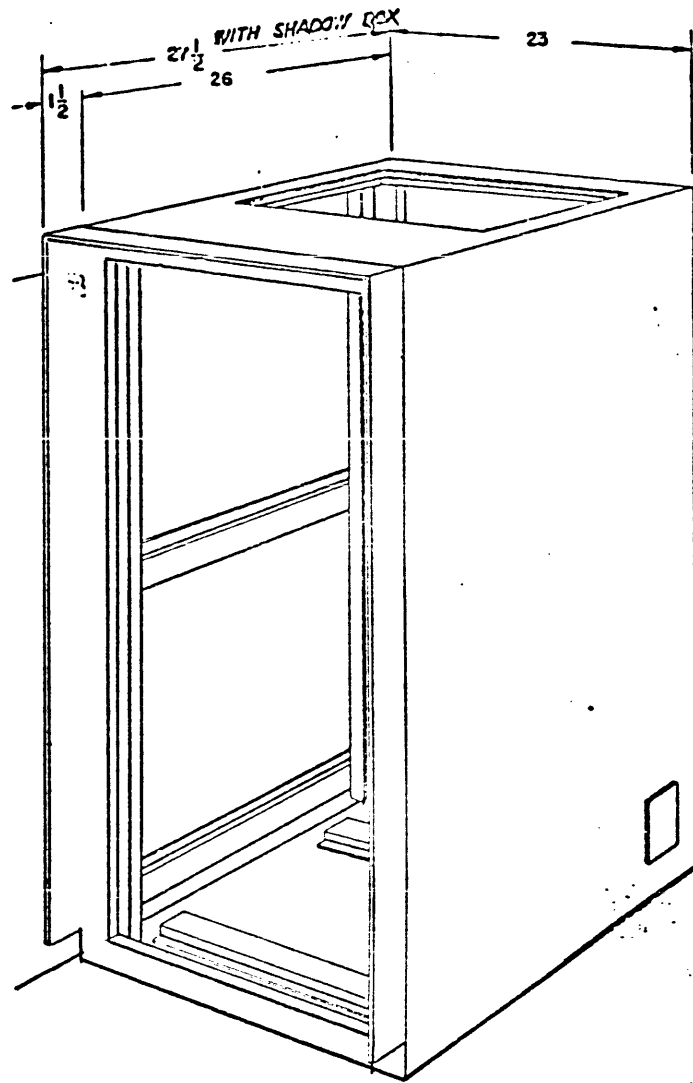

Figure 2-1 Outline Dimensions Model SYM1205

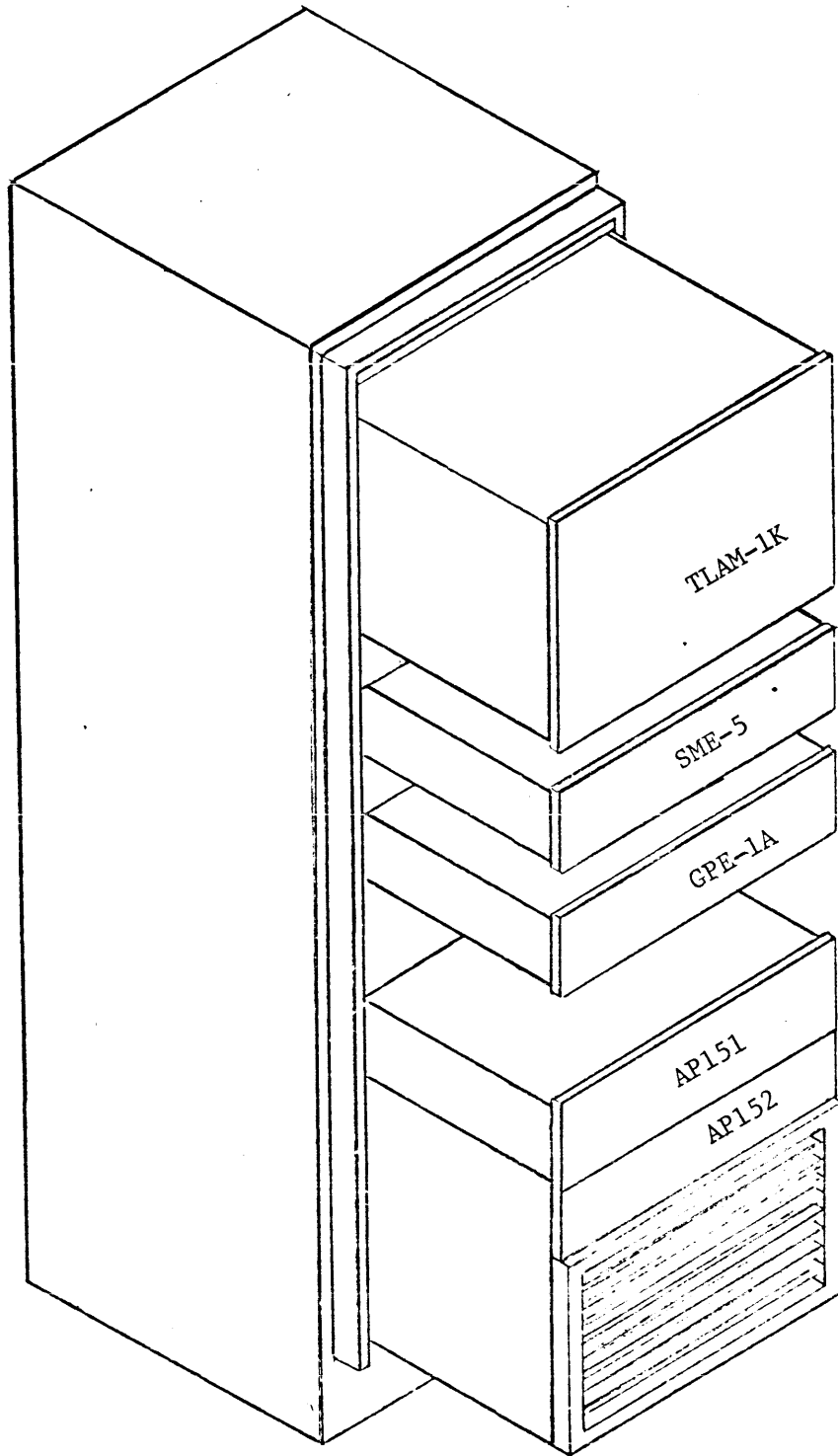
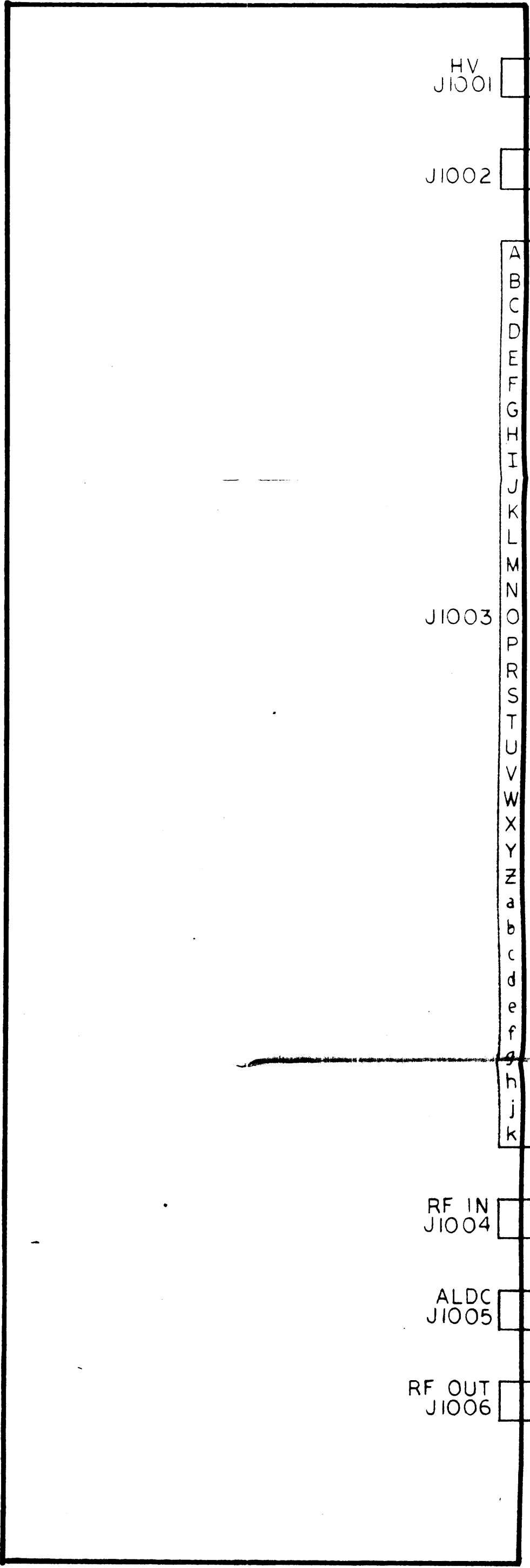

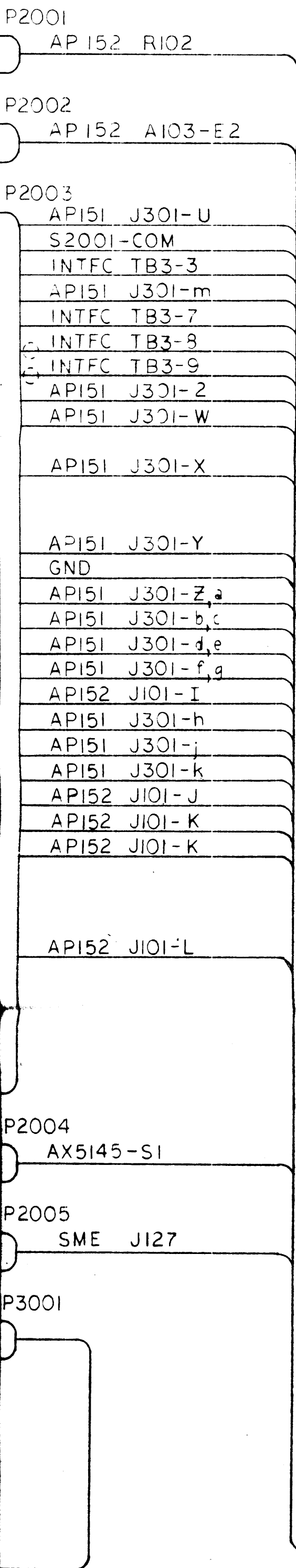

Figure 2-2 Typical Installation Of SYM1205

TLAM-1K



P3002
 RF OUT J2002  CA480-36-XX



AX5145

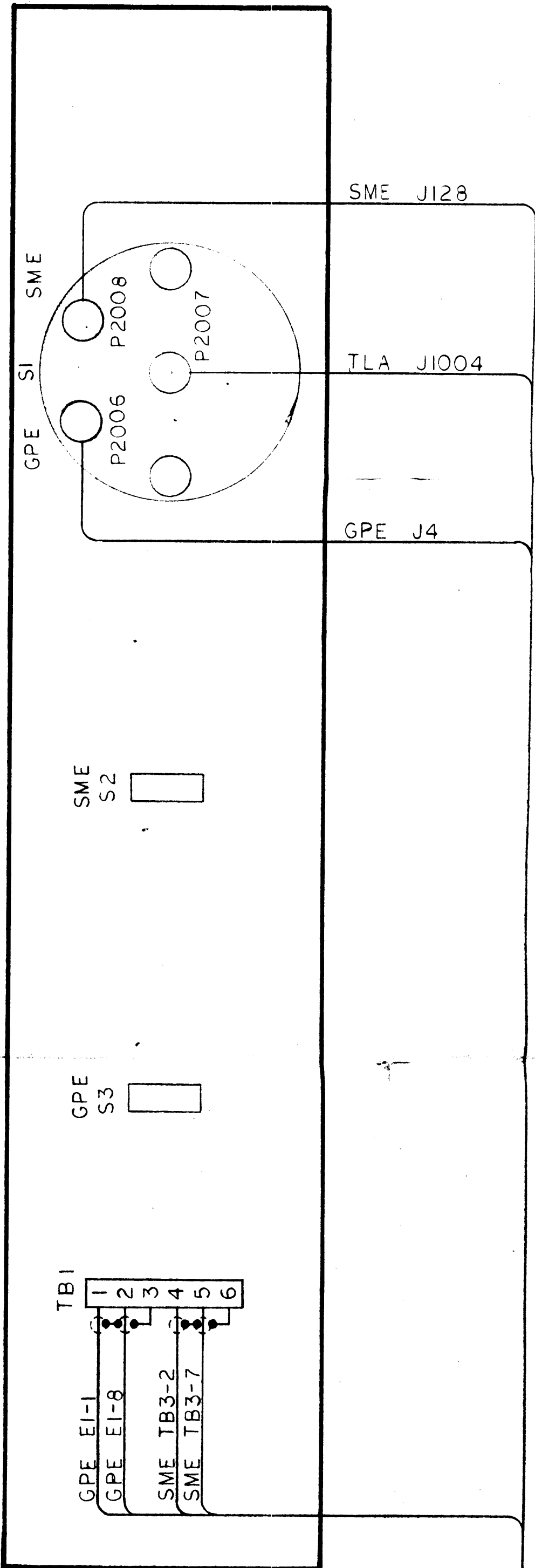

SME-5

CA1706

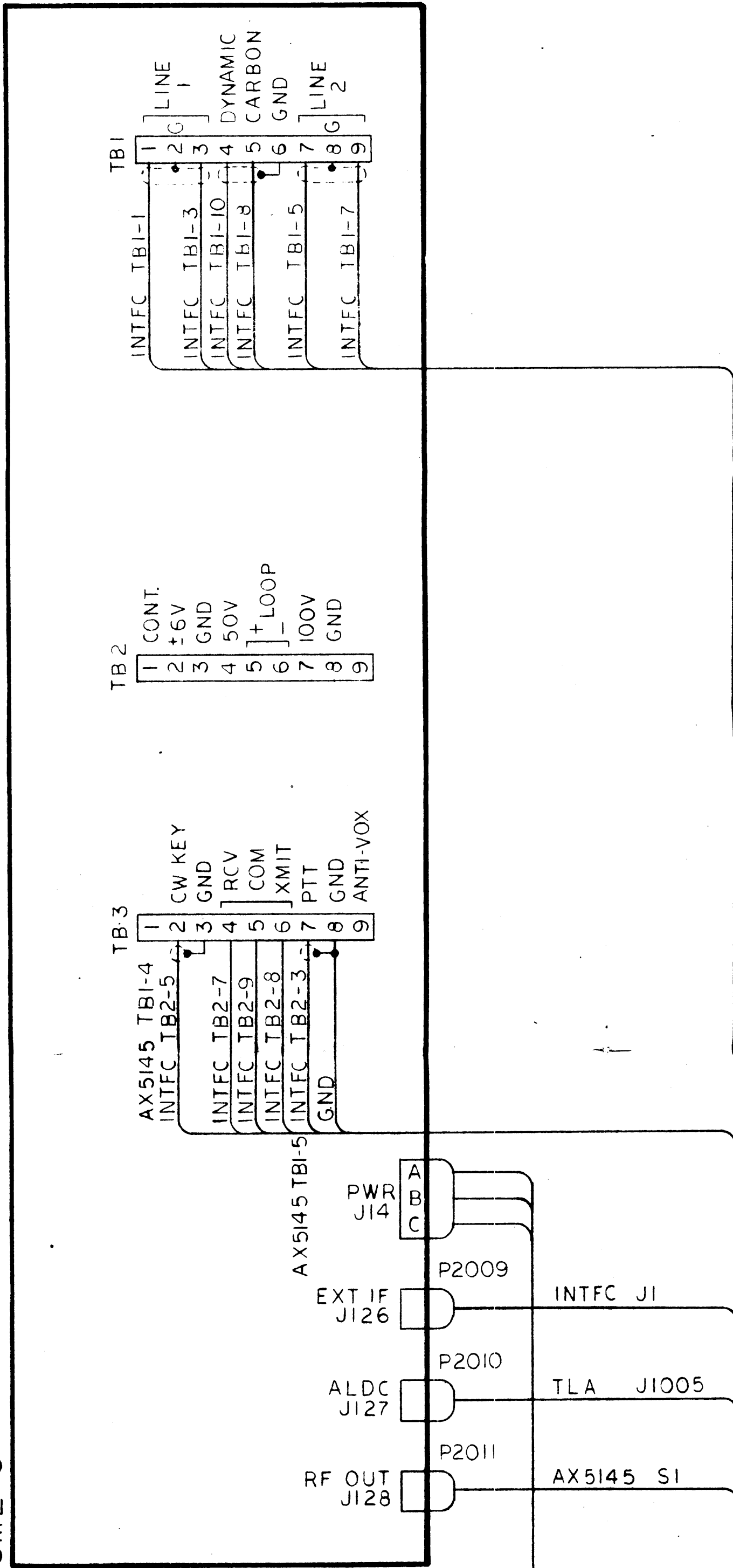

GPE-1A

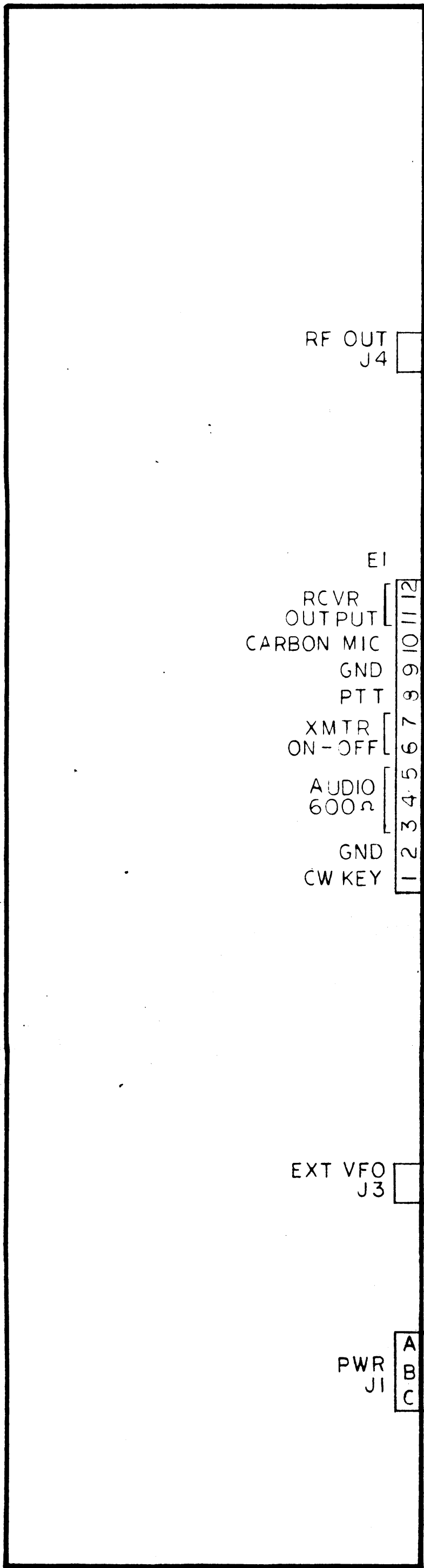

RF OUT J4 P2012 AX5145 S1

EI
RCVR OUTPUT [11
CARBON MIC [10
GND [9
PTT [8
XMTR ON-OFF [7
[6
AUDIO 600Ω [5
[4
[3
GND [2
CW KEY [1

INTFC TB5-5
GND
INTFC TB6-1, AX5145 TBI-2
INTFC TB6-6
INTFC TB6-5
INTFC TB5-3
INTFC TB5-2
INTFC TB5-1
INTFC TB6-3, AX5145 TBI-1

EXT VFO J3 P2013 INTFC J2

PWR J1 A B C

J1003

J
K
L
M
N
O
P
R
S
T
U
V
W
X
Y
Z
a
b
c
d
e
f
g
h
j
k

AP
AP
GN
AP
AP
AP
AP
AP
AP
AP
AP
AP
AP
AP
AP

AP

TLAM-1K

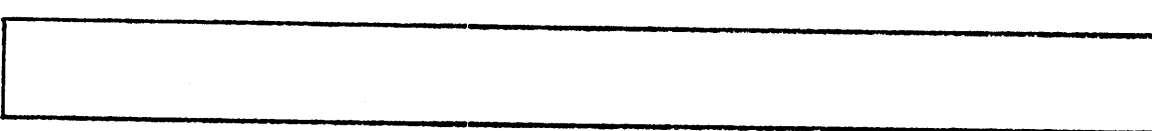
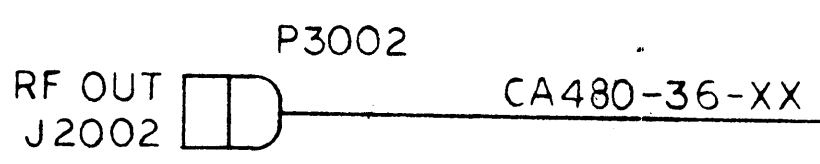
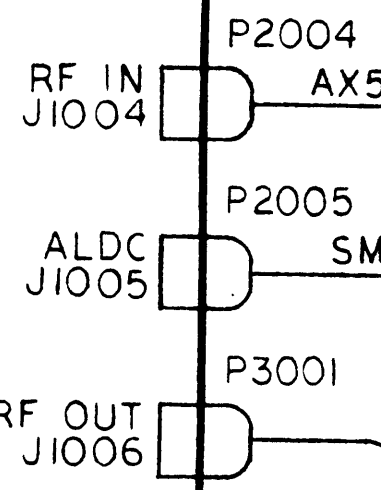

API51 J301-X
API51 J301-Y
GND
API51 J301-Z_a
API51 J301-b_c
API51 J301-d_e
API51 J301-f_g
API52 J101-I
API51 J301-h
API51 J301-j
API51 J301-k
API52 J101-J
API52 J101-K
API52 J101-K

API52 J101-L

2004
AX5145-S1

2005
SME J127

3001



AX 5145

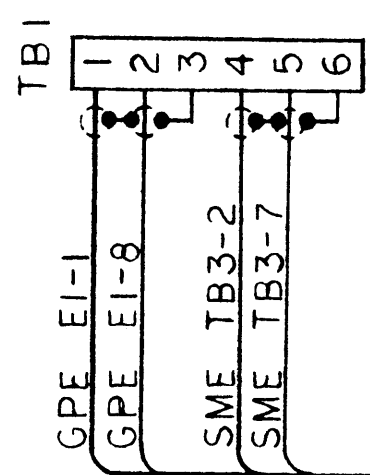

SME
S2

GPE
S3

GPE J4

SME-5

CA1706

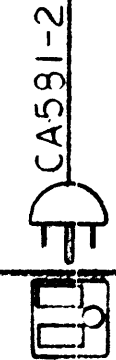
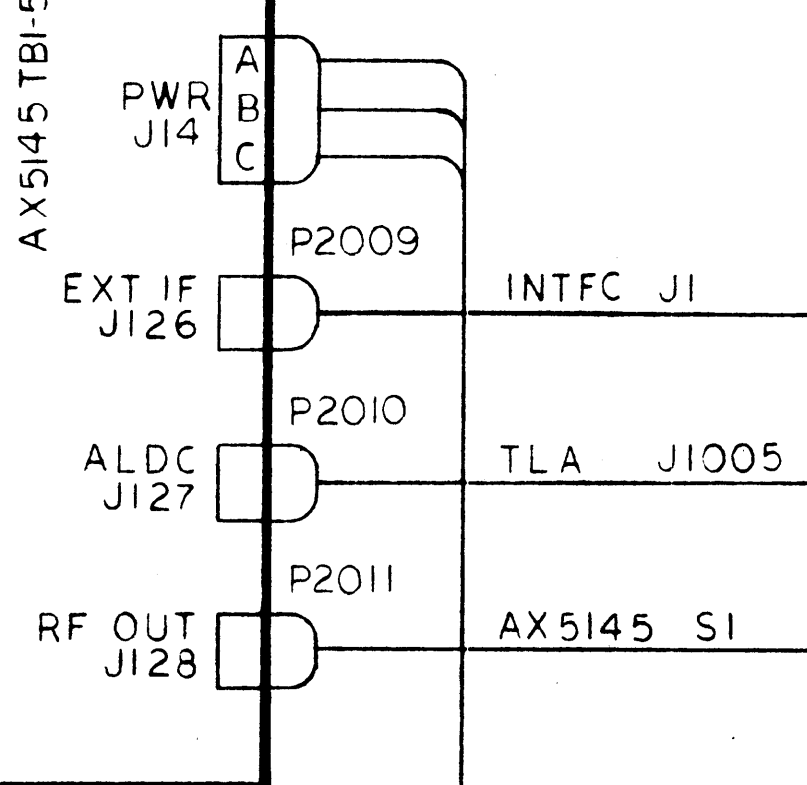
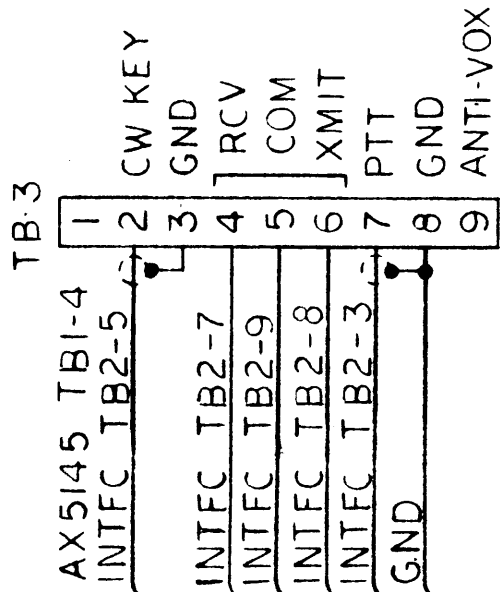
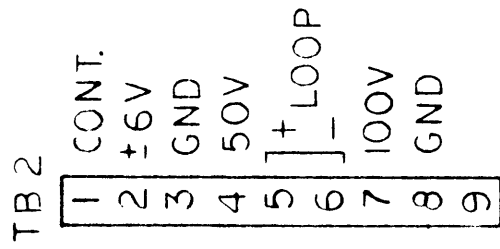

REVISIONS							
ZONE	LTR	DESCRIPTION	DATE	E.M.N.NO	DRAFT	CHKD	APPD
	Ø	FOR APPROVAL	5/30/72		EP		

NOTICE TO PERSONS RECEIVING
 THE TECHNICAL MATERIEL CORPORATION claims propie
 This drawing is issued in confidence for engineering informa
 to manufacture anything shown hereon without permission fr
 to the user. This drawing is loaned for mutual assistance an

QTY	MODEL
	SYM 1205

GPE-1A

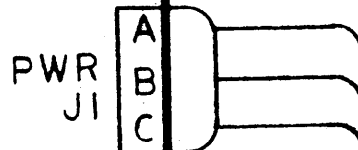
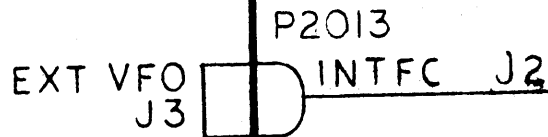
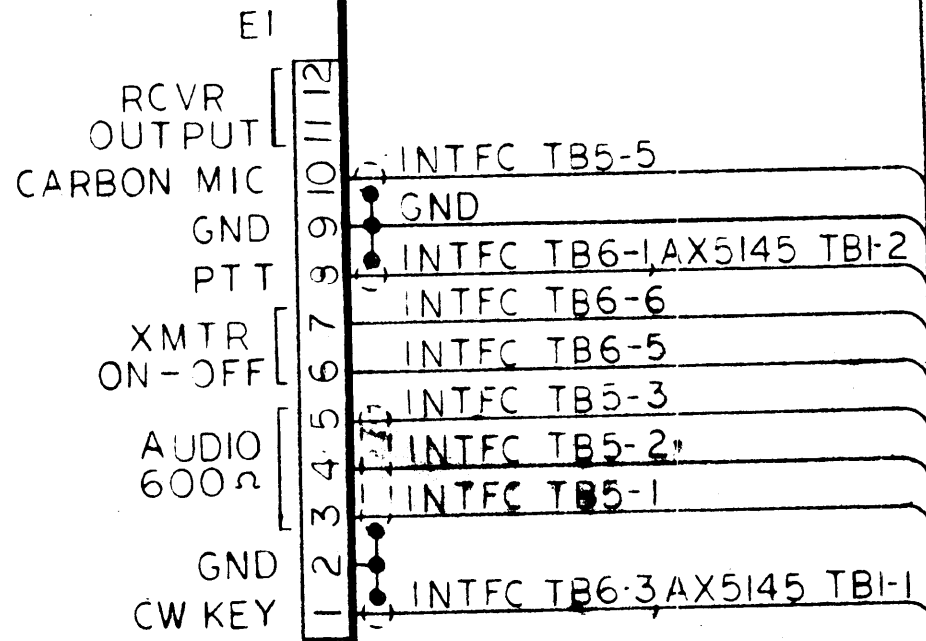

TO SHEET 2

NOTICE TO PERSONS RECEIVING THIS DRAWING
 THE CORPORATION claims proprietary right in the material disclosed hereon. Confidence for engineering information only and may not be reproduced or used herein without permission from THE TECHNICAL MATERIEL CORPORATION. It is looked for mutual assistance and is subject to recall at any time.

MODEL
 M 1205

FINAL APPROVAL <i>[Signature]</i>	DATE 24 May 72
MECH. DES.	DATE
ELECT. DES. <i>[Signature]</i>	DATE 24 May 72
CHECKED <i>[Signature]</i>	DATE 24 May 72
DRAWN <i>[Signature]</i>	DATE 18 APR 72

THE TECHNICAL MATERIEL CORP.
 MAMARONECK, NEW YORK

DIAGRAM, WIRING
TRANSMITTING SYSTEM
SYM 1205

SIZE CODE IDENT. NO.
82679

SCALE

Figure 2-3
 (Sheet 1 of 2)

API51 J301-2
API52 J101-F

001-NC

A J1003-H

API52

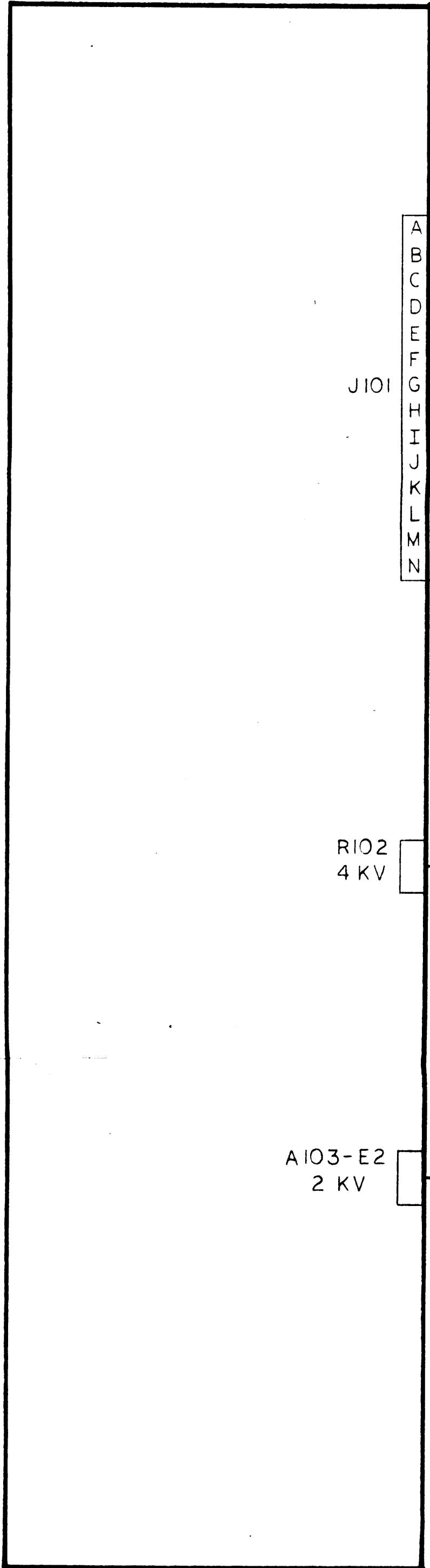

CA1706

J101

A
B
C
D
E
F
G
H
I
J
K
L
M
N

P2015

J2001 AC STRIP

J2001 AC STRIP

GND

API51 J301-D

API51 J301-R

API51 J301-E

TLA J1003-U

TLA J1003-Y

TLA J1003-Z, a

TLA J1003-e

API51 J301-F

API51 J301-G

R102
4 KV

TLA J1001

A103-E2
2 KV

TLA J1002

INTERFACE PANEL

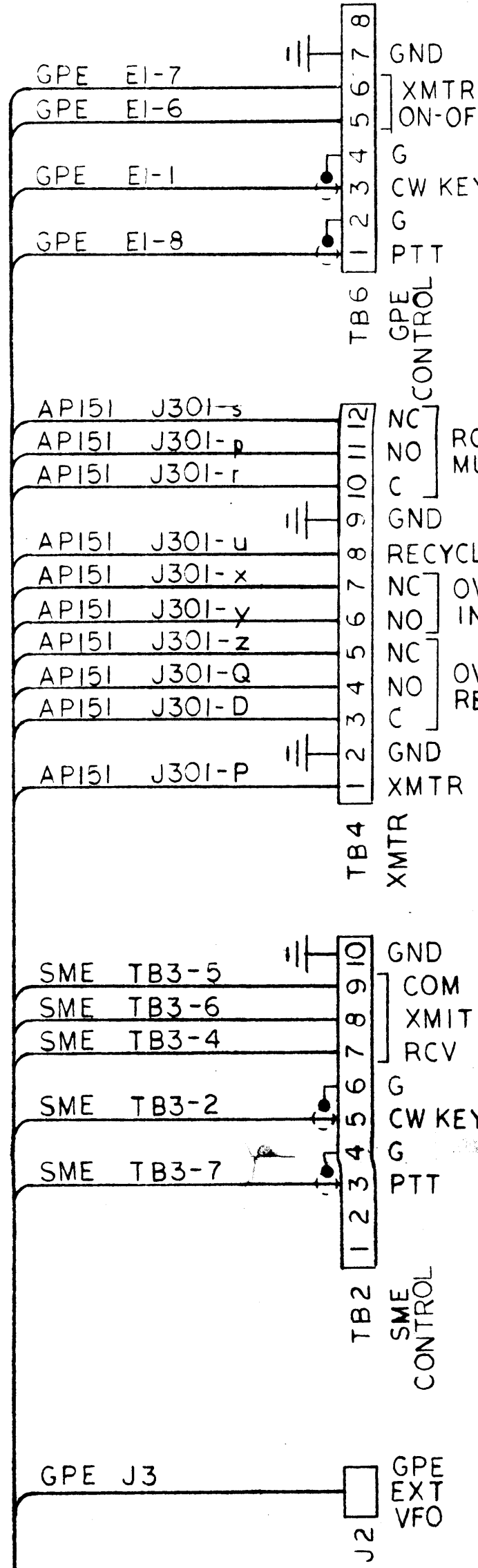
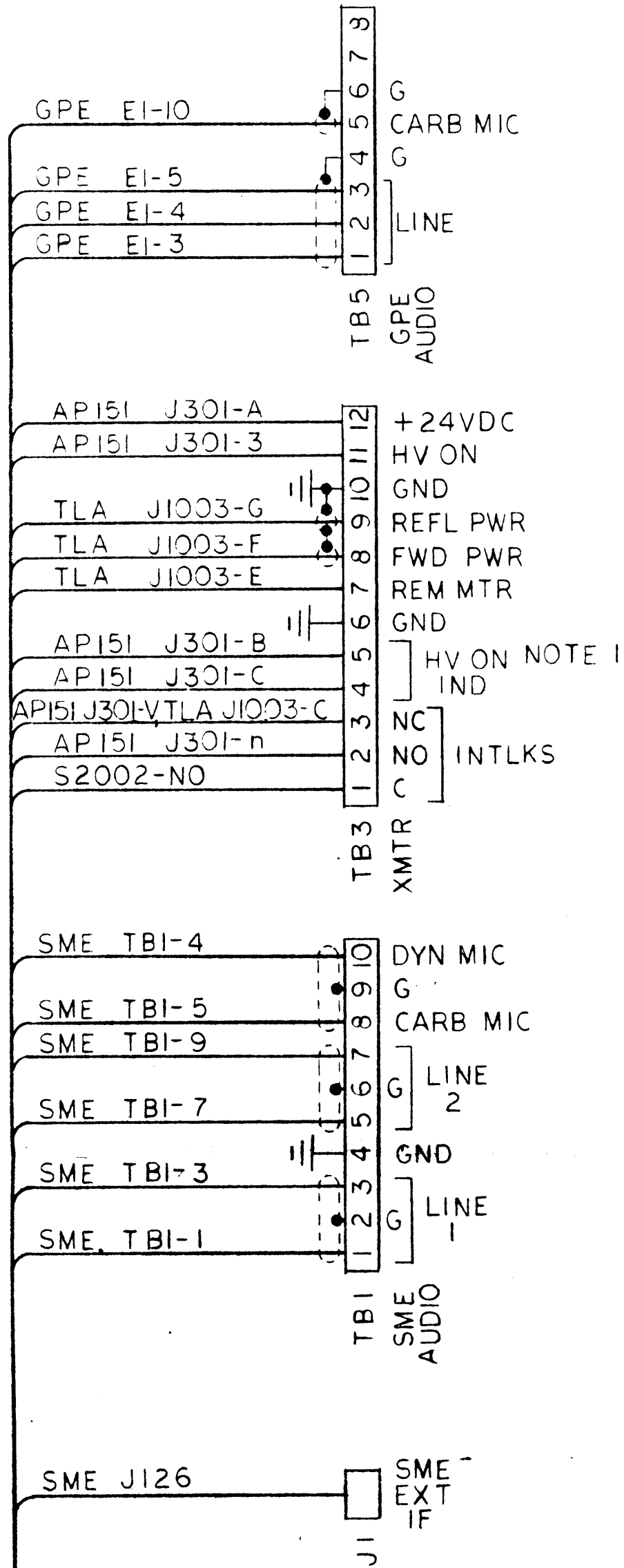

1. HV ON INDICATOR IS FOR A SERIE CONNECTED 24VDC DEVICE.
2. RCVR MUTE TERMINAL DESIGNATIONS ARE FOR XMTR OFF CONDITION.
3. OVLD IND TERMINAL DESIGNATIONS ARE FOR OVERLOAD CONDITION.
4. OVLD RESET TERMINAL DESIGNATIONS ARE FOR AN INACTIVATED SWITCH.

THE FOLLOWING TERMINALS MUST BE JUMPED IF THEY ARE NOT CONNECTED TO EXTERNAL LINES:

TB2-3	—	TB2-4	SME PTT
TB2-5	—	TB2-6	SME CW KEY
TB2-8	—	TB4-1	XMTR ON
TB2-9	—	TB2-10	XMTR ON
TB3-1	—	TB3-2	INTERLOCKS
TB3-10	—	TB3-11	HV ON
TB4-3	—	TB4-5	OVLD RESET
TB6-1	—	TB6-2	GPE PTT
TB6-3	—	TB6-4	GPE CW KEY
TB6-5	—	TB4-1	XMTR ON
TB6-6	—	TB6-7	XMTR ON

ND
 XMTR
 ON-OFF
 W KEY
 TT
 CONTROL
 RCVR
 MUTE
 GND
 RECYCLE
 OVLD
 IND
 OVLD
 RESET
 GND
 XMTR PTT
 GND
 COM
 XMIT
 RCV
 CW KEY
 PTT
 CONTROL
 GPE
 EXT
 VFO

NOTE 2

NOTE 3

NOTE 4

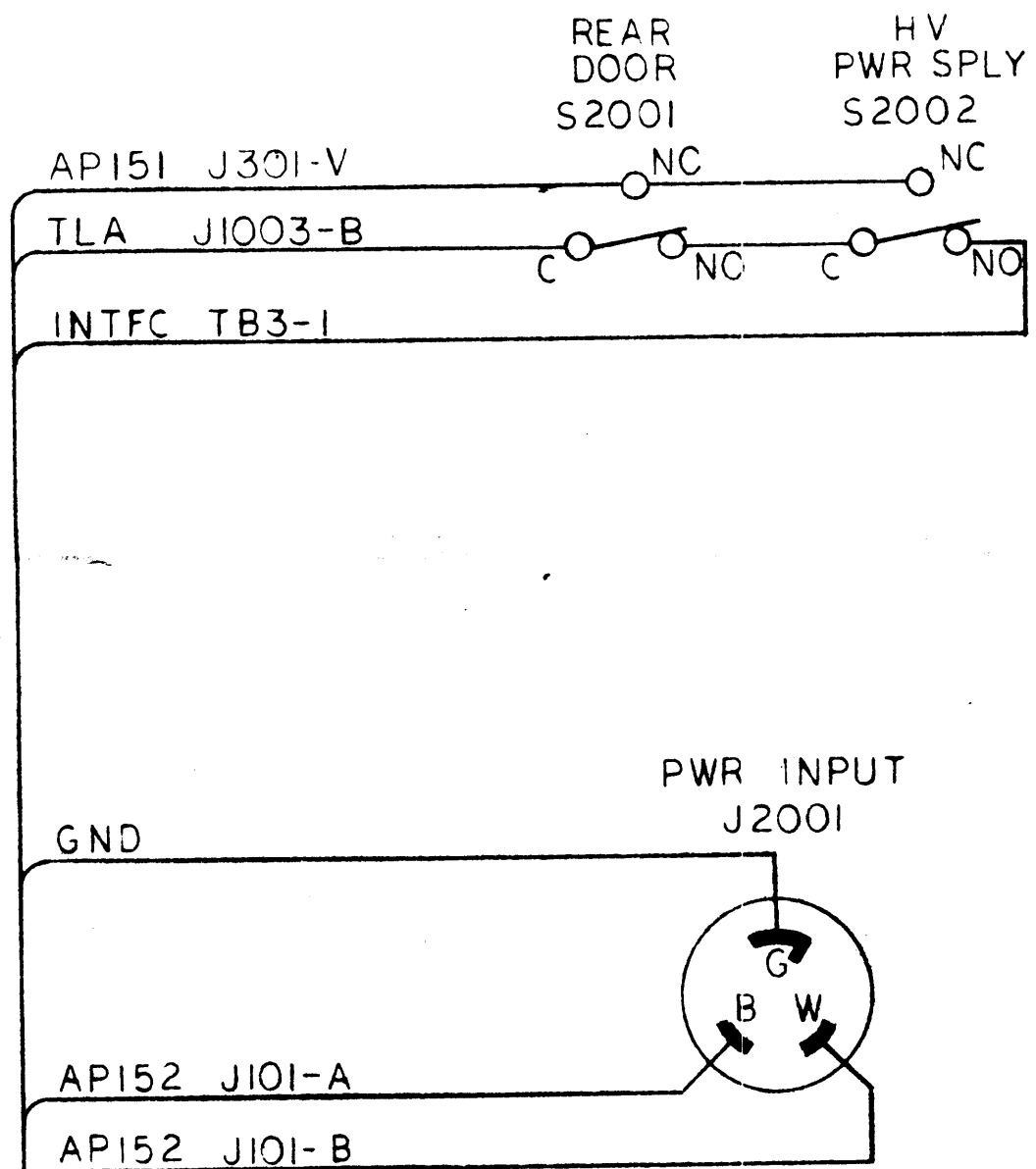

LAST SYMBOLS
J2002
P2015
S2002
P3002

Q
R
S
T
U
V
W
X
Y
Z
a
b
c
d
e
f
g
h
i
j
k
l
m
n
p
r
s
t
u
v
w
x
y
z
2
3
4
5
6

INTFC TB4-4
API52 J101-G
TLA J1003-A
INTFC TB3-3, S2001-NC
TLA J1003-I
TLA J1003-K
TLA J1003-N
TLA J1003-P
TLA J1003-P
TLA J1003-R
TLA J1003-R
TLA J1003-S
TLA J1003-S
TLA J1003-T
TLA J1003-T
TLA J1003-T
TLA J1003-V
TLA J1003-W
TLA J1003-X
TLA J1003-D
INTFC TB3-2
INTFC TB4-11
INTFC TB4-10
INTFC TB4-12
INTFC TB4-8
INTFC TB4-7
INTFC TB4-6
INTFC TB4-5
API51 J301-CTLA J1003-H
INTFC TB3-11
GND

J301

API51

TO
SHEET 1

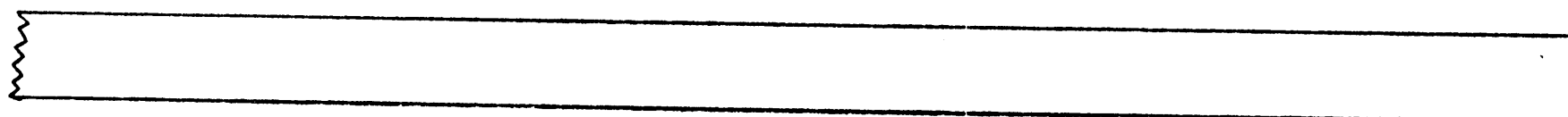

2001-NC

LA J1003-H

K
L
M
N

TLA J1003-Z, a
TLA J1003-e
API51 J301-F
API51 J301-G

R102
4 KV

TLA J1001

A103-E2
2 KV

TLA J1002

API52

CA1706



API52 J101-A,B

INTERFACE PANEL

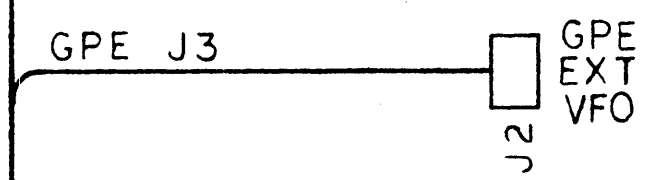
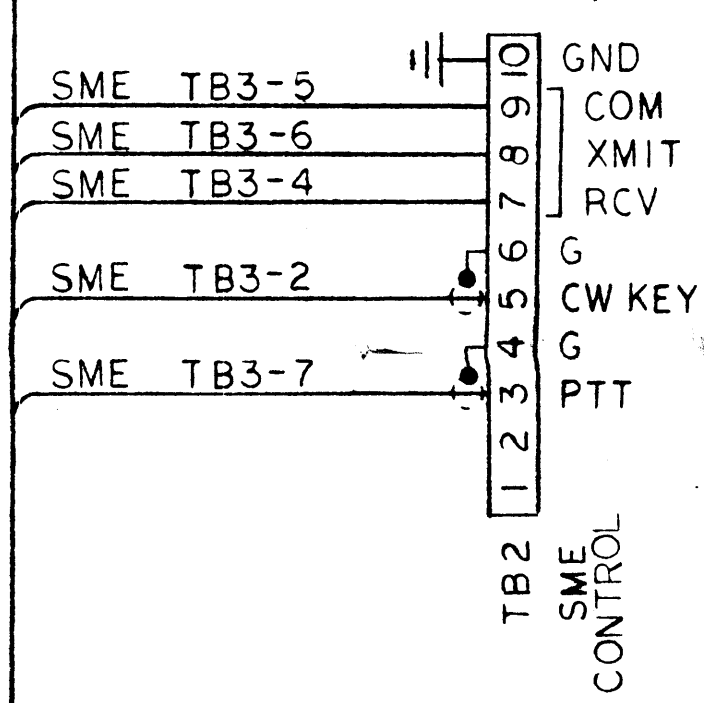
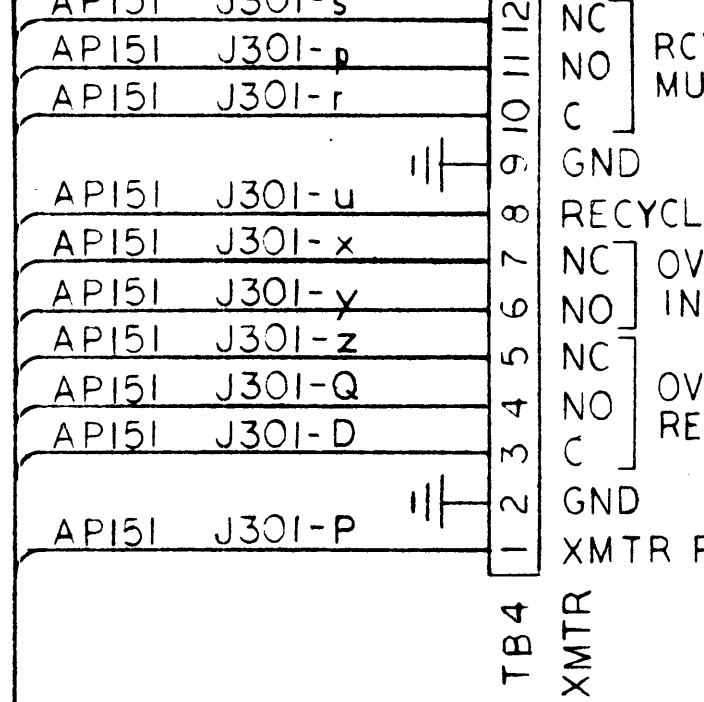
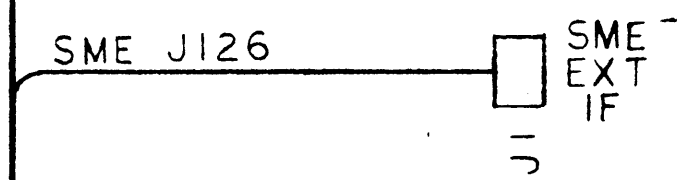
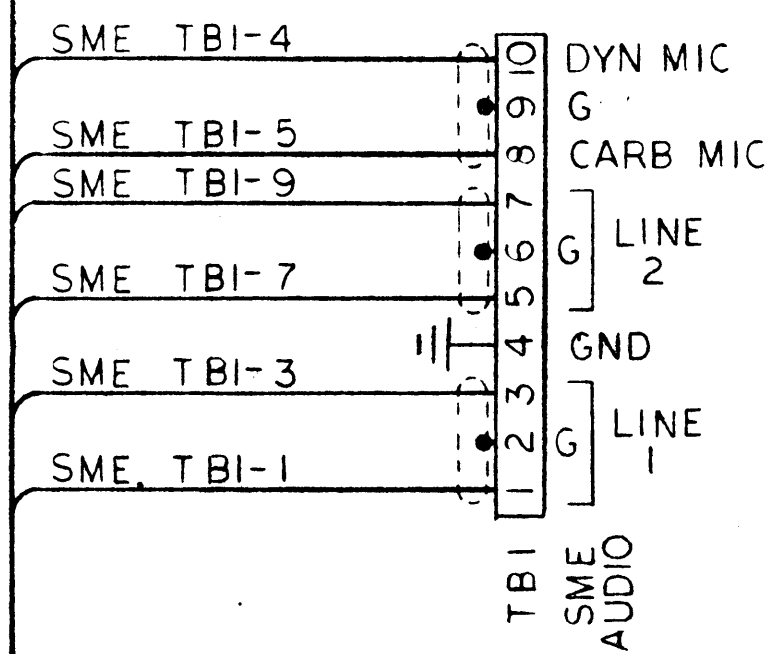
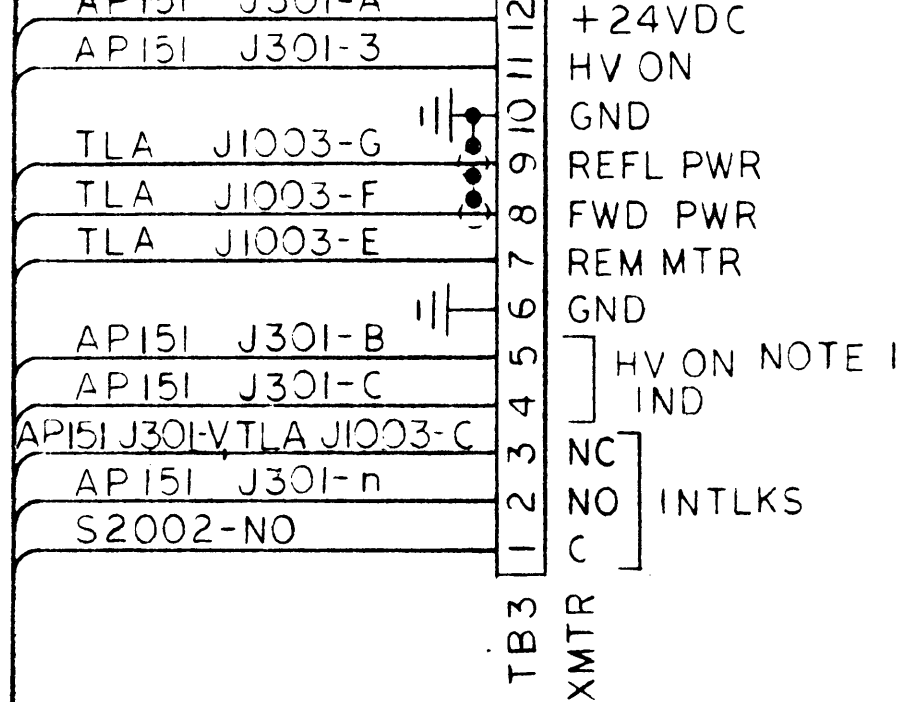

REVISIONS							
ZONE	LTR	DESCRIPTION	DATE	E.M.N.NO	DRAFT	CHKD	APPD
	Ø	ORIGINAL RELEASE FOR PRODUCTION	5-30-72		ef		

NOTICE TO PERSONS
 THE TECHNICAL MATERIEL CORPORATION
 This drawing is issued in confidence for engineering
 to manufacture anything shown hereon without permission
 to the user. This drawing is loaned for mutual use.

QTY	MODEL
	SYM 1205

NOTE 2
 RCVR MUTE
 ND
 RECYCLE
 NOTE 3
 OVLD IND
 NOTE 4
 OVLD RESET
 ND
 XMTR PTT
 ND
 COM
 XMIT
 RCV
 G
 CW KEY
 PTT
 SIME CONTROL
 GPE EXT VFO

TB6-3 — TB6-4 GPE CW KEY
 TB6-5 — TB4-1 XMTR ON
 TB6-6 — TB6-7 XMTR ON

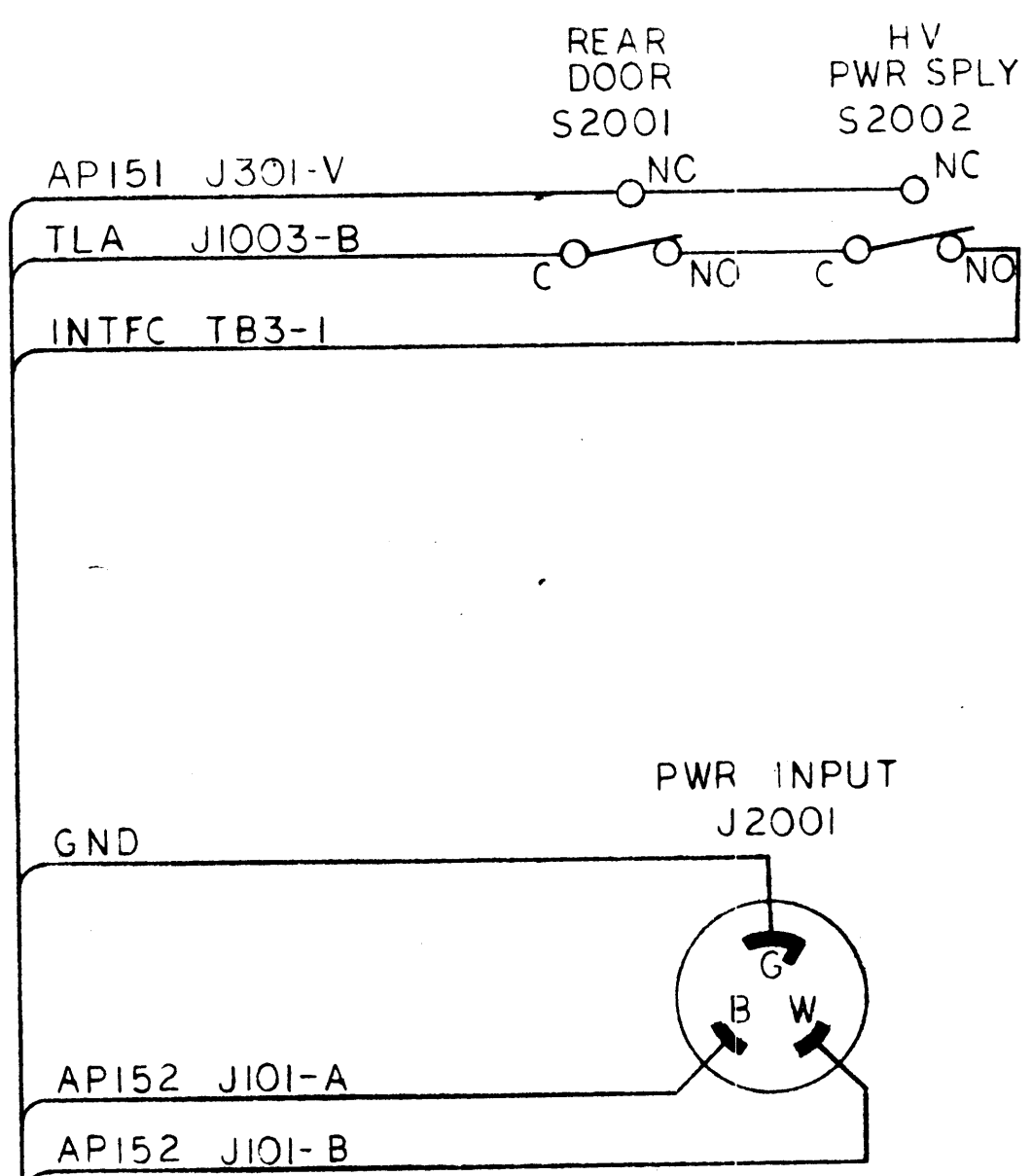

LAST SYMBOLS
J2002
P2015
S2002
P3002

NOTICE TO PERSONS RECEIVING THIS DRAWING
 CORPORATION claims proprietary right in the material disclosed hereon.
 for engineering information only and may not be reproduced or used
 person without permission from THE TECHNICAL MATERIEL CORPORATION
 for mutual assistance and is subject to recall at any time.

DEL
 1205

FINAL APPROVAL <i>[Signature]</i>	DATE 24 May 72
MECH. DES.	DATE
ELECT. DES. <i>[Signature]</i>	DATE 24 May 72
CHECKED <i>[Signature]</i>	DATE 24 May 72
DRAWN <i>[Signature]</i>	DATE 12 APR 72

THE TECHNICAL MATERIEL CORP.
 MAMARONECK, NEW YORK

DIAGRAM, WIRING
 TRANSMITTING SYSTEM
 SYM 1205

SIZE	CODE IDENT. NO.
	82679
SCALE	

Figure 2-3
 (Sheet 2 of 2)

SECTION 3
OPERATOR'S SECTION

3-1. GENERAL

The controls of each exciter unit provide rapid transmitter rf frequency selection of AM, SSB, CW and MCW intelligence in the 2 MHz to 30 MHz transmission range.

3-2. OPERATING CONTROLS

For detailed functions of all operating controls and indicators of the transmitter, refer to the applicable HFLM-1K, GPE-1A and SME-5 technical manuals.

3-3. STARTING CONTROL SETTINGS

Generally, before main power is applied all operating controls should be set at OFF or maximum counterclockwise position. Starting control settings are provided in table 3-1.

3-4. OPERATING PROCEDURE

Typical operation of the transmitter is provided in table 3-2 and 3-3 which illustrates the manual tuning procedure for CW operation. Typical examples are given in tables 3-2 and 3-3 using the GPE-1A exciter on a carrier frequency of 5.680 MHz, and the SME-5 exciter on a carrier frequency of 9.130 MHz.

Once the exciter has been adjusted for the desired type of intelligence and emission mode, the application of drive must be carefully adjusted to avoid exceeding the rated PEP output of the transmitter. Refer to table 3-5 for typical control settings to be used as a guide for tuning.

TABLE 3-1. STARTING CONTROL SETTINGS

<u>Modular Unit</u>	<u>Control</u>	<u>Setting</u>
AP152	MAIN POWER circuit breaker	OFF
AP151	SCREEN and PLATE circuit breaker	OFF
	ALARM switch	down, OFF position

TABLE 3-1. STARTING CONTROL SETTINGS (continued)

<u>Modular Unit</u>	<u>Control</u>	<u>Setting</u>
GPE-1A	OUTPUT control	maximum counterclockwise
	METER switch	OUTPUT position
	EMISSION switch	CW key
	PWR off MODULATION sw.	clockwise slightly to light POWER lamp
SME-5	UPPER SIDEBAND switch	OFF
	LOWER SIDEBAND switch	OFF
	PTT/VOX switch	PTT
	MODE switch	CW
	POWER ON/OFF	OFF
AX5145	EXCITER RF OUTPUT	GPE-
	GPE- TEST KEY	UP(locked)
TLAM-1K	ALDC control	maximum counterclockwise
	LOAD control	0 position
	OVERLOAD adjustment	600 ma

TABLE 3-2. TRANSMITTER OPERATING PROCEDURE
(with GPE-1A Exciter)

<u>Step</u>	<u>Operation</u>	<u>Normal Indications</u>
1	Place HFLM-1K MAIN POWER breaker to the ON position.	PA Blower must operate and MAIN POWER ON must illuminate. Interlock lamp lights (provided that all safety interlocks are closed and the time delay cycle has been completed).
2	Set PLATE and SCREEN breakers to ON position.	No indications
3	Set XTAL switch to position that contains the 2.840 KHZ crystal and set BAND switch to 4-8 MHz position.	No indications

TABLE 3-2. TRANSMITTER OPERATING PROCEDURE (continued)
(with GPE-1A Exciter)

<u>Step</u>	<u>Operation</u>	<u>Normal Indications</u>
4	Adjust OUTPUT control clockwise to cause GPE-1A meter to indicate 1/4 scale. Adjust TUNING control in the vicinity of the crystal frequency (approximately 2.8 on front panel).	GPE-1A meter will indicate the highest reading when TUNING control is properly tuned.
5	Place HFLM-1K ALARM ON/OFF switch to OFF position.	With alarm switch in the ON position and high voltage removed due to an overload, audible high voltage alarm sounds.
6	Set HFLM-1K RF GAIN to minimum.	No indications.
7	Adjust HFLM-1K overload indicator (adjustment screw located directly below the meter face of the PLATE current meter) for 600 ma.	HFLM-1K PLATE current overload indicator indicates 600 ma.
8	Select frequency BAND position by rotating the HFLM-1K BAND knob to a band within the desired frequency.	Window on HFLM-1K front panel indicates desired frequency band.
9	Adjust HFLM-1K PA Bias, 1ST AMP and 2ND AMP Bias for maximum bias.	PA, 1ST AMP and 2ND AMP Bias adjusted to maximum clockwise position. (Bias adjustment controls located in Low voltage P/S).
10	Press HFLM-1K HIGH VOLTAGE switch to light indicator (it may be necessary to press HIGH VOLTAGE switch twice).	HIGH VOLTAGE switch and HIGH VOLTAGE ON indicator lamp illuminate RED when High Voltage is ON.
11	Adjust HFLM-1K PA Bias control to a value between 210-230 ma on PLATE METER.	HFLM-1K PLATE meter indicates quiescent current between 210-230 ma.
12	Push HFLM-1K PLATE METER SELECT switch up and adjust 2nd AMP for indications of 220-240 ma on PLATE meter.	HFLM-1K PLATE meter indicates quiescent current of 220-240 ma when PLATE METER SELECT switch is pushed up.

NOTE

Steps 9 thru 13 should be performed on initial transmitter turn ON or if transmitter has been off for a long period of time

During initial tuning of the transmitter, RF output power will be increased or decreased with the HFLM-1K RF GAIN control.

TABLE 3-2. TRANSMITTER OPERATING PROCEDURE (continued)
(with GPE-1A Exciter)

<u>Step</u>	<u>Operation</u>	<u>Normal Indications</u>
13	Adjust HFLM-1K 1ST AMP Bias control to a 60-70 ma indication on PLATE meter.	HFLM-1K PLATE meter reads between 60-70 ma when PLATE METER SELECT switch is pushed down.
14	Adjust HFLM-1K RF GAIN control clockwise slightly to cause a notable increase in PA PLATE current.	HFLM-1K PLATE meter indicates an increase in meter reading not to exceed 300 ma.
15	Adjust HFLM-1K TUNE control for a noticeable resonant dip in Plate current.	Rotation of the HFLM-1K TUNE control causes the KILOWATT OUTPUT meter to indicate output.
16	Adjust HFLM-1K LOAD control as necessary to produce a maximum reading on the KILOWATT METER.	HFLM-1K KILOWATT meter indicates a further increase in power output during loading process.
17	Readjust TUNE control to insure that the transmitter is at resonance. Repeat steps 15 and 16 as necessary.	KILOWATT meter indicates highest value when transmitter is properly tuned into antenna or load.
18	Rotate HFLM-1K RF GAIN control clockwise to increase output power to desired level. (Refer to HFLM-1K technical manual for ALDC adjustment.)	KILOWATT meter indicates average power output level. (1 kilowatt output maximum). Refer to Table 3-4 for Transmitter Output Indications.
19	Set TEST KEY on AX5145 to center position.	KILOWATT meter indicates zero when TEST KEY is open.

NOTE

The transmitter may be CW keyed via a telegraph key inserted in front panel KEY jack or by connecting a telegraph key to interface terminals (3) and (4) on TB6. Exciter control positions for other emission modes (AM, MCW) are outlined in the GPE-1A technical manual.

TABLE 3-3. TRANSMITTER OPERATING PROCEDURE
(with SME-5 Exciter)

<u>Step</u>	<u>Operation</u>	<u>Normal Indications</u>
1	Set power ON/OFF switch to ON position.	POWER lamp on SME-5 must light.
2	Select operating frequency of 9.130 MHz by setting the CHANNEL select switch to position 3.	No indication.
3	Set MODE switch to CW position and set LOWER and UPPER SIDE BAND switches to the OFF positions.	
4	Set EXCITER RF OUTPUT switch to SME position and press SME TEST KEY to UP position (lock).	SME CW KEY LINE is closed via TEST KEY.
5	Place transmitter MAIN POWER breaker to ON position.	Same as Step 1 in Table 3-2.
6	Perform steps 5 thru 19 outlined in Table 3-2.	

TABLE 3-4. TRANSMITTER OUTPUT INDICATIONS

<u>Emission Mode</u>	<u>Kilowatt Output Meter</u>
CW	1 KW
AM	approx. 250 watts
LSB	approx. 500 watts
USB	approx. 500 watts
AME	approx. 250 watts
FSK	1 KW

TABLE 3-5. TYPICAL TRANSMITTER TUNING CHART

FREQUENCY (MHz)	BAND (MHz)	TUNE CONTROL COUNTER READINGS	LOAD CONTROL*	PLATE CURRENT (MA)
2.3	2.0-2.6	131	4.0	380
2.8	2.6-3.0	138	4.0	380
4.0	3.0-5.0	109	0	320
6.0	5.0-8.0	101	6.8	340
8.0	8.0-12.0	104	6.8	400
11.0	8.0-12.0	078	6.2	340
14.0	12.0-16.0	078	2.2	360
16.0	16.0-24.0	094	1.2	340
20.0	16.0-24.0	078	1.8	450
24.0	24.0-30.0	082	1.0	420
28.0	24.0-30.0	072	1.0	520

*Maximum counterclockwise position is LOAD control setting of 0;
maximum clockwise is setting of 12.

SECTION 4

MAINTENANCE & TROUBLESHOOTING

4-1. PREVENTIVE MAINTENANCE

Preventive Maintenance is that kind of maintenance that should be performed during idle periods of operation or at periodic intervals. Since the transmitter system primarily consist of three major units interconnected to form a dual exciter transmitting system preventive maintenance can be performed on an operation level.

The following signal frequencies and their respective voltage levels should be monitored periodically to detect the possibility of early failure due to incorrect frequency or voltage levels:

(A) At J128 (on rear of SME-5) measure the frequency and output level of the SME-5 output signal. (Refer to SME-5 Technical Manual)

(B) At J4 (on rear of GPE-1A) measure the frequency and level of the GPE-1A output signal. (Refer to GPE-1A Technical Manual)

(C) At J2002 (RF OUTPUT) measure carrier frequency of the overall system at a specific operating frequency using the GPE-1A exciter or the SME-5 exciter. (Refer to Figure 4-1)

4-2. ALIGNMENT

The transmitter system is designed for long term trouble free use, however when the need arises for parts replacement and/or alignment due to component aging, first determine which major unit that is causing the malfunction (refer to Table 4-1). After it is determined that a major unit (HFLM-1K or exciter units) is at fault refer to the Maintenance Section of that modular unit technical manual for detailed P/C card and overall alignment procedures.

4-3. CORRECTIVE MAINTENANCE

During OFF THE AIR periods the following listed items should be checked, replaced or cleaned as necessary to insure proper operation:

(A) Rotate front panel Selector switches clockwise through each position and insure proper operation.

(B) Clean switch contacts with vacuum cleaner or some suitable switch contact cleaner.

(C) Replace all chipped or broken knobs and toggle switches.

(D) Check terminal strips on the interface panel and insure that all external connections are properly made and tight.

(E) Remove top and bottom dust covers on modular units and observe chassis for obvious charred or burnt components, replace as necessary (refer to modular manual for part replacement and alignment procedures involved before replacing P/C card components).

(F) Check front panel meters (Ip, OUTPUT/MODULATION and LSB/USB) for proper operation, mechanical zero, broken meter face or bent indicators, replace or repair as necessary.

4-4. TROUBLESHOOTING

This paragraph provides information that enables a technician to troubleshoot the transmitter on a system level. Refer to Table 4-1 Troubleshooting guide for localization of transmitter malfunction if necessary. WHEN IT BECOMES NECESSARY TO TAKE VOLTAGE MEASUREMENT USE EXTREME CAUTION.

TABLE 4-1

TROUBLESHOOTING TABLE

<u>MALFUNCTION</u>	<u>PERFORM OPERATION</u>
MAIN POWER lamp does not light when MAIN POWER breaker is ON.	(1) Check MAIN POWER lamp. (2) Check that proper line voltage is applied to PWR INPUT jack J2001. (3) Measure line voltage at MAIN POWER breaker or MAIN POWER lamp, voltage should be same as line voltage.
INTERLOCK lamp does not light with power applied to transmitter.	(1) Insure that rear door interlock and H.V. power supply interlock are closed. (2) Connect a short jumper at TB3 terminals (1) & (2). (If INTERLOCK lamp lights, external interlock circuit is open.) (3) Check TLAM-1K top & bottom cover interlock switches, (remove top & bottom covers and pull interlock switch shaft outward to close switch with covers off.) (4) Check that PA blower is operating and the air switch is closed. (5) Check for presence of 24vdc at Z1101 located in TLAM-1K or +24vdc at CR303 located in the Low Voltage power supply. (6) Check DC fuses or L.V. fuses.
MAIN POWER breaker trips when set to ON position.	(1) Check POWER input connections. (2) Check MAIN POWER breaker.
H.V. Indicator does not light when H.V. button pressed twice.	Check the following: (1) PLATE & SCREEN breakers must be in ON position. Interlock lamp must be lit.

TABLE 4-1 (cont)

TROUBLESHOOTING TABLE

MALFUNCTION

PERFORM OPERATION

	<p>(2) Check interface panel, the following terminals must be connected via jumper connection or switch device:</p> <table border="0"> <tr> <td>TB3 (10)(11)</td> <td>H.V. ON</td> </tr> <tr> <td>TB4 (3)(5)</td> <td>OVERLOAD RESET</td> </tr> <tr> <td>TB3 (1)(2)</td> <td>INTERLOCKS</td> </tr> </table> <p>(3) Set bias controls to maximum clockwise position, press H.V. switch and check that "Ip" meter is not lit. (When "Ip" meter lamp lights it indicates an overload condition).</p> <p>(4) Observe High Voltage relay K101 located in the H.V. power supply, K101 should energize when H.V. switch is pressed. If K101 does not energize check for the following:</p> <ol style="list-style-type: none"> a. K101 defective relay coil. b. 24vdc on XK101 pin (7) and ground on pin (6) when H.V. button is pressed. c. The ground connection for K101 is routed through the contacts (14)&(15) of Overload Reset relay K2, mounted on PC598 located in the L.V. power supply. Refer to AP151 and AP152 schematic diagrams for point to point connections. 	TB3 (10)(11)	H.V. ON	TB4 (3)(5)	OVERLOAD RESET	TB3 (1)(2)	INTERLOCKS
TB3 (10)(11)	H.V. ON						
TB4 (3)(5)	OVERLOAD RESET						
TB3 (1)(2)	INTERLOCKS						
PLATE SCREEN breakers trip.	<p>(1) Check that RF GAIN control on TLAM-1K is set at max counterclockwise.</p> <p>(2) Reset Plate & Screen breakers, and should breakers continue to trip perform the following:</p> <ol style="list-style-type: none"> a. Remove RF Amplifier tubes V1201, V1202 and V1301. (Remove tubes one at a time Reset breaker after the removal of a tube. Should the breaker remain in reset (ON) position after the removal of a tube, change that tube. <p>(3) Refer to AP152 (H.V. Power Supply schematic and check rectifier assemblies A101 & A102.</p>						
High Voltage ON no indication on "Ip" meter.	<p>(1) Check PA, 2ND Amp & 1ST Amp bias adjustments. (Refer to paragraph 5-7 in HFLM-1K technical manual.</p> <p>(2) Check transmitter PTT circuit. Remove external PTT devices and provide a short jumper to Interface TB4 terminal (1) & (2).</p> <p>(3) If PTT circuit is ok, refer to Table 5-4 in HFLM-1K technical manual.</p>						

TABLE 4-1 (cont)

TROUBLESHOOTING TABLE

<u>MALFUNCTION</u>	<u>PERFORM OPERATION</u>
SWR overload trips. (indicated by SWR meter lamp lit)	(1) Turn transmitter H.V. OFF and check transmission line for bad connection, open line or shorted line. (2) Check antenna for proper termination. (3) Terminate transmitter output into a 50 ohm dummy load and tune transmitter. (4) If SWR excessive into dummy load check directional coupler located in TLAM-1K.
NO transmitter output (High Voltage is on Ip reading normal)	Check for the following: (1) PA bandswitch at correct setting for selected operating frequency? (2) Exciter RF OUTPUT switch in proper position for exciter that is used? (3) RF Gain control on TLAM-1K adjusted for transmitter output? (4) ALDC control should be max counterclockwise on initial tune-up. (5) Check external keyline or audio input connections. (6) Remove P2004 (RF IN plug). Terminate exciter into dummy load and refer to modular SME-5 or GPE-1A technical manuals for normal exciter output indications.

NOTE

Once it has been determined that an exciter (SME-5 or GPE-1A) is the cause of transmitter malfunction (such as no output, incorrect frequency, no modulation, etc.) refer to the applicable exciter technical manual for troubleshooting and alignment procedures.

4-5. PARTS REPLACEMENT

Replacement parts list are supplied for each modular unit within the transmitter. When it becomes necessary for parts replacement, note the schematic reference designation for the defective component, refer to the modular unit technical manual parts list section for the correct part number. Obtain component from spare parts or order from factory.

When it becomes necessary to replace a variable component bear in mind that, upon removal note the position or setting of front panel indicator (counter, band indicator, control knob rotation clockwise or counterclockwise) and insure that the replaced components is at the correct position when installed in transmitter.

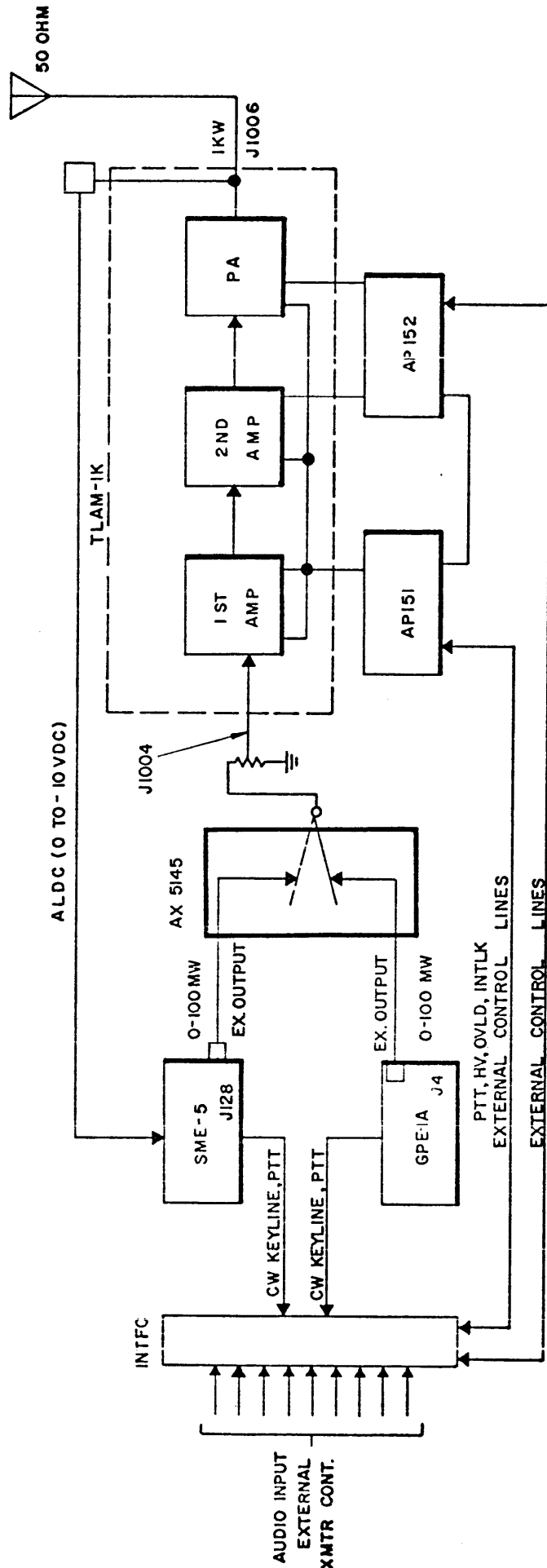

Figure 4-1 System Functional Block Diagram

PARTS LIST
SYM 1205

REF SYMBOL	DESCRIPTION	TMC PART NUMBER
	Switch Panel Assembly	AX5145*
J2001	Connector, Receptacle, AC	JJ297-1
J2002	Adaptor, HN	UG1019*U
S2001	Switch, Interlock	SW230
S2002	Same as S2001	
TB1	Terminal Strip Barrier	TM100-10
TB2	Same as TB1	
TB3	Terminal Strip Barrier	TM100-12
TB4	Same as TB3	
TB5	Terminal Strip Barrier	TM100-8
TB6	Same as TB5	
	AX 5145	
S1	Switch, Coaxial	SW239
S2	Switch, Lever	SW523-2
S3	Same as S2	
TB1	Terminal Board Barrier	TM102-6