

REVISIONS						
ZONE	LTR	DESCRIPTION	DATE	E.M.N.NO	DRAFT	CHKD APPD
	x	EXPERIMENTAL RELEASE	9/11/68		C.V.	<i>[Signature]</i>
	Ø	ORIG. RELEASE FOR PROD	11/19/68	Ø	R.G.	<i>[Signature]</i>

CHASSIS MOUNTING DATA

CONTACT DATA							
TMC CODE	DESCRIPTION	CHASSIS THICK.	X-DIM.	BELOW CHASSIS CAT #	BELOW CHASSIS CODE #	ABOVE CHASSIS CAT #	ABOVE CHASSIS CODE #
S	SOLDER CUP	1/16	.44	HRP-1	1	HRP-2	2
		3/32	.41	HRP-31	31	HRP-32	32
		1/8	.38	HRP-41	41	HRP-42	42
T	TURRET	1/16	.44	HRP-3	3	HRP-4	4
		3/32	.41	HRP-33	33	HRP-34	34
		1/8	.38	HRP-43	43	HRP-44	44

SPECIFICATIONS

ELECTRICAL

WIRE SIZE:  
 SOLDER CUP TYPE: ONE #16 AWG OR TWO #20 AWG  
 TURRENT TYPE: TWO #16 AWG OR THREE #20 AWG  
 CURRENT RATING: 13 AMPERES

MECHANICAL

CREEPAGE BETWEEN CONTACTS: 1/8" MINIMUM  
 AIR SPACE BETWEEN CONTACTS: 1/16" MINIMUM  
 CONTACTS: SPRING TEMPER GRADE "A" PHOSPHOR BRONZE.  
 GOLD PLATED OVER SILVER PLATE  
 MOUNTING HARDWARE: SPECIAL STUDS, SCREWS, LOCKWASHER,  
 AND NUTS  
 TEMPERATURE RATINGS: -65°C TO +125°C  
 WEIGHT OF SOCKET WITH MOUNTINGS: 1.54 OZ.

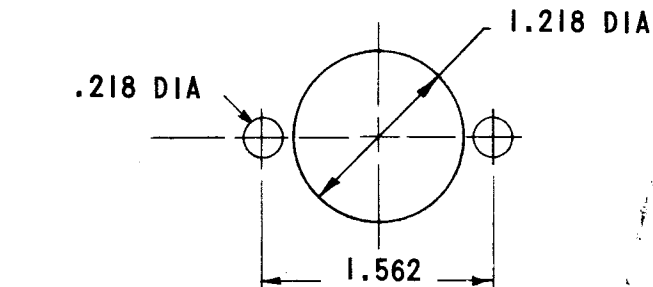
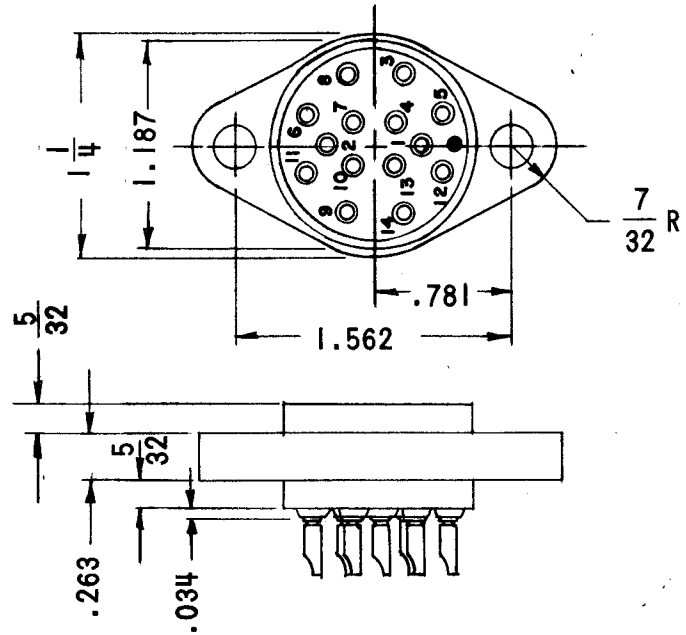

TMC PART NUMBER SHALL APPEAR IN THE FOLLOWING FORMAT:

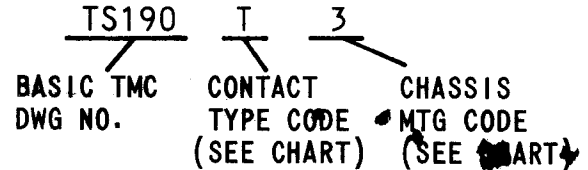

REQ'D	ITEM	PART NUMBER	DESCRIPTION	SYM.
-------	------	-------------	-------------	------

LIST OF MATERIAL

QTY / UNIT	MODEL USED ON	ASS'Y NO.
	RTTD-4	
APPLICATION		
	CODE	S401-471

**NOTICE TO PERSONS RECEIVING THIS DRAWING**  
 THE TECHNICAL MATERIEL CORPORATION claims proprietary right in the material disclosed hereon. This drawing is issued in confidence for engineering information only and may not be reproduced or used to manufacture anything shown hereon without permission from THE TECHNICAL MATERIEL CORPORATION to the user. This drawing is loaned for mutual assistance and is subject to recall at any time.

UNLESS OTHERWISE SPECIFIED DIMENSIONS ARE IN INCHES AND INCLUDE CHEMICALLY APPLIED OR PLATED FINISHES

DECIMALS	FRACTIONS
.X ± .05	1/64
.XX ± .01	TOLS. ANGLES
.XXX ± .005	0° .30'

FINAL APPROVAL	DATE
<i>[Signature]</i>	11/19/68
MECH. DES.	DATE
<i>[Signature]</i>	11/19/68
ELECT. DES.	DATE
<i>[Signature]</i>	10/9/68
CHECKED	DATE
<i>[Signature]</i>	8-20-68
DRAWN	DATE
<i>[Signature]</i>	

THE TECHNICAL MATERIEL CORP.

MAMARONECK, NEW YORK

SOCKET, RELAY

SIZE	CODE IDENT. NO.	DWG NO.	ISSUE
B	82679	TS 190	Ø
SCALE	SHEET		OF
	1		