

TMC NO.	S-401-176 CAT. NO. (SEE NOTE 2)	C	L	NO. OF TERMINALS	S-401-223 CAT. NO. (SEE NOTE 1&2)
TM-105-2--	2-160-B	.375	1 7/16	2	
TM-105-3--	3-160-B	.750	1 13/16	3	
TM-105-4--	4-160-B	1.125	2 3/16	4	
TM-105-5--	5-160-B	1.500	2 9/16	5	
TM-105-6--	6-160-B	1.875	2 15/16	6	
TM-105-7--	7-160-B	2.250	3 5/16	7	
TM-105-8--	8-160-B	2.625	3 11/16	8	
TM-105-9--	9-160-B	3.000	4 1/16	9	
TM-105-10--	10-160-B	3.375	4 7/16	10	
TM-105-11--	11-160-B	3.750	4 13/16	11	
TM-105-12--	12-160-B	4.125	5 3/16	12	
TM-105-13--	13-160-B	4.500	5 9/16	13	
TM-105-14--	14-160-B	4.875	5 15/16	14	
TM-105-15--	15-160-B	5.250	6 5/16	15	
TM-105-16--	16-160-B	5.625	6 11/16	16	
TM-105-17--	17-160-B	6.000	7 1/16	17	
TM-105-18--	18-160-B	6.375	7 7/16	18	
TM-105-19--	19-160-B	6.750	7 13/16	19	
TM-105-20--	20-160-B	7.125	8 3/16	20	
TM-105-21--	21-160-B	7.500	8 9/16	21	
TM-105-22--	NOT AVAIL	7.875	8 15/16	22	22CS14
TM-105-25--	NOT AVAIL	9.000	10 1/16	25	23CS14

J
TM-105

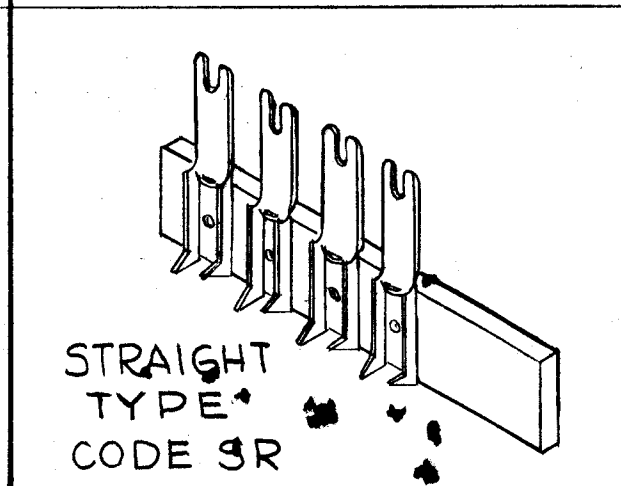
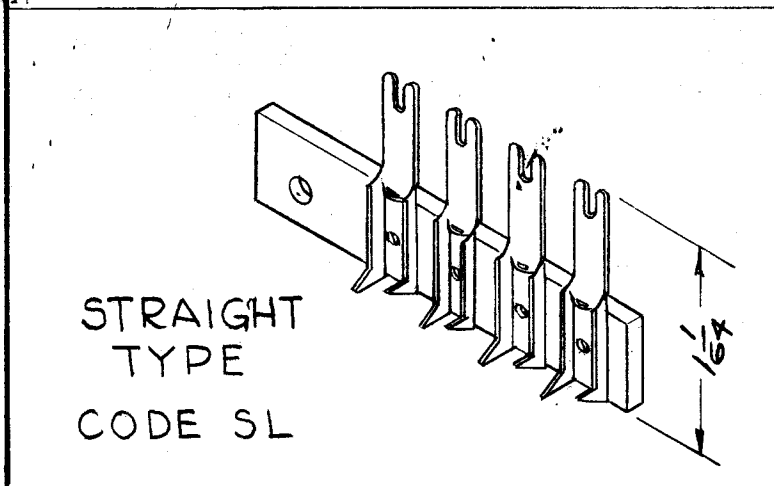
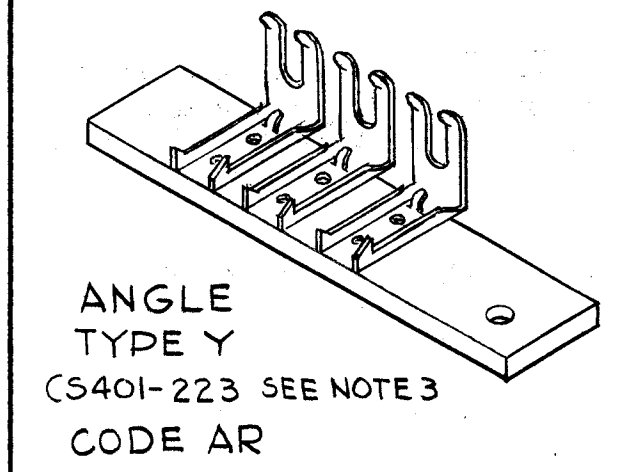
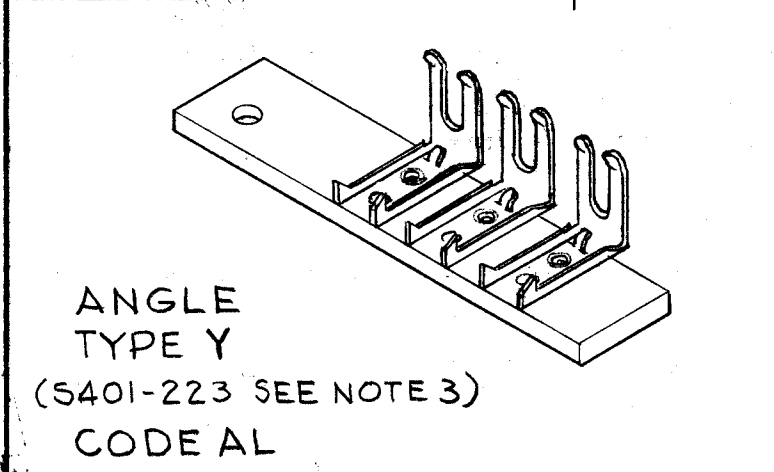
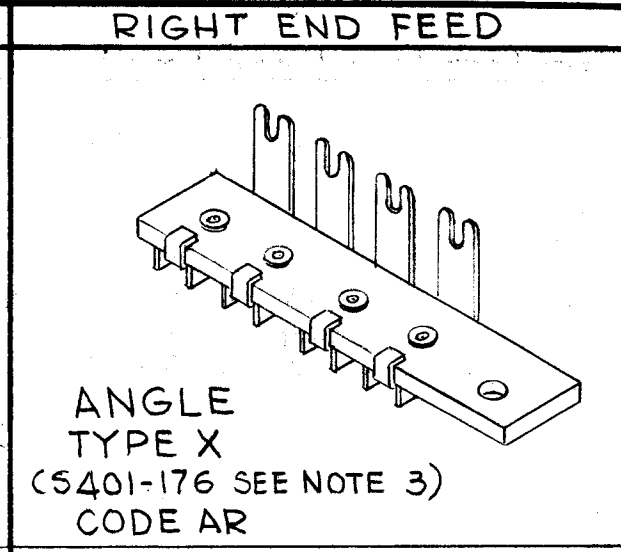
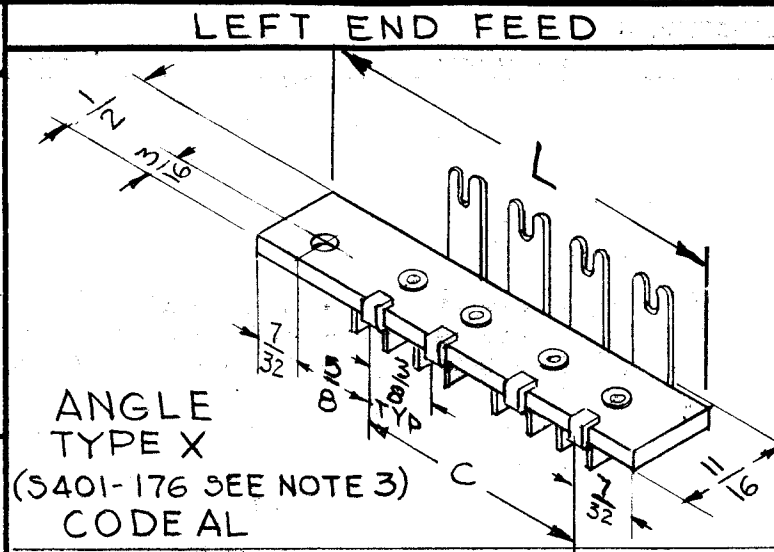

- NOTE:
- S-401-223 AVAILABLE ONLY AS ANGLE TYPE, i.e. AR OR AL (TYPE Y)
 - WHEN PURCHASING - ADD ANGLE AND FEED LETTER DESIGNATIONS TO MFG. NUMBER.
 - ANGLE TYPE X OR Y BOTH ACCEPTABLE

TYPE DESIGNATION SHALL BE IN FOLLOWING FORM

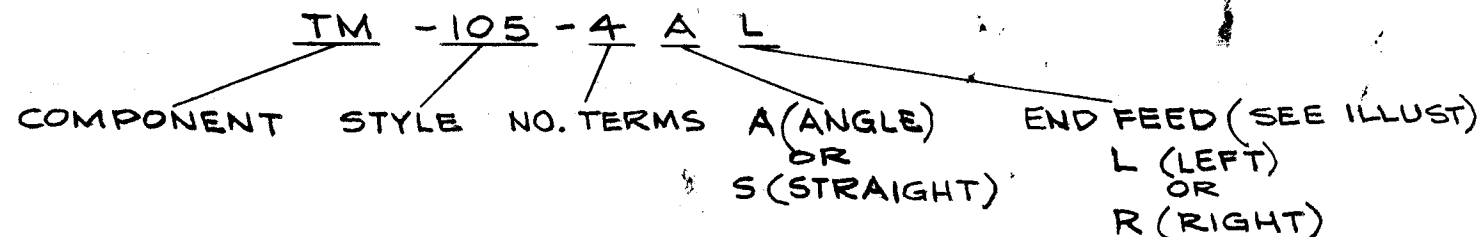

REQ'D.	ITEM	PART NUMBER	DESCRIPTION	SYMBOL
J. CAMARDA LIST OF MATERIAL				
MATERIAL		BLACK PHENOLIC		
FINISH		THE TECHNICAL MATERIEL CORP. MAMARONECK, NEW YORK		
TITLE		TERMINAL BOARD, FANNING TYPE		
UNLESS OTHERWISE SPECIFIED DIMENSIONS ARE IN INCHES AND INCLUDE CHEMICALLY APPLIED OR PLATED FINISHES		DRAWN G.D.L.	DATE 9-11-63	FINAL APPROVAL
		CHECKED	DATE 9-12-63	
DECIMALS .X ± .05 .XX ± .01 .XXX ± .005		FRACTIONS ± 1/64 ANGLES ± 0° 30'		TOLERANCES
THE CONTENTS OF THIS DRAWING ARE THE EXCLUSIVE PROPERTY OF THE TECHNICAL MATERIEL CORP. ITS UNAUTHORIZED USE OR REPRODUCTION IN WHOLE OR IN PART IS STRICTLY FORBIDDEN.		ELECT. DES.		MECH. DES.
		DATE		DATE
		SHEET		REV. LTR.

SYM	DESCRIPTION	DATE	CH. NO.	DRAFTS	CHECKER	ENG. APP.
J	CAT. NOS. 2CS14 THRU 21CS14 DELE.	8.10.64	12085		WB	J.P.
H	REDRAWN & REVISED	9-12-63	9717		J.P.	WB

UNLESS OTHERWISE SPECIFIED DIMENSIONS ARE IN INCHES AND INCLUDE CHEMICALLY APPLIED OR PLATED FINISHES

SCALE

Q'TY./UNIT SCALE NONE

MODEL USED ON CODE S-401-176 S-401-223

ASS'Y. NO.

DECIMALS .X ± .05 .XX ± .01 .XXX ± .005

FRACTIONS ± 1/64 ANGLES ± 0° 30'

TOLERANCES

CODE