

TMC P/N	TIME Cycle	
TI101-1		TIME DIAL CYCLE DIVISION WATTS
TI101-2	60 Sec.	See PO341-2
TI101-3		
TI101-4	5 MIN	See PO341-1
TI101-5	5 MIN	15 sec

REVISIONS						
ZONE	LTR	DESCRIPTION	DATE	E.M.N.NO	DRAFT	CHKD APPD
	G	Redrawn & REVISED from (2) SIZE	3-24-82	21985		

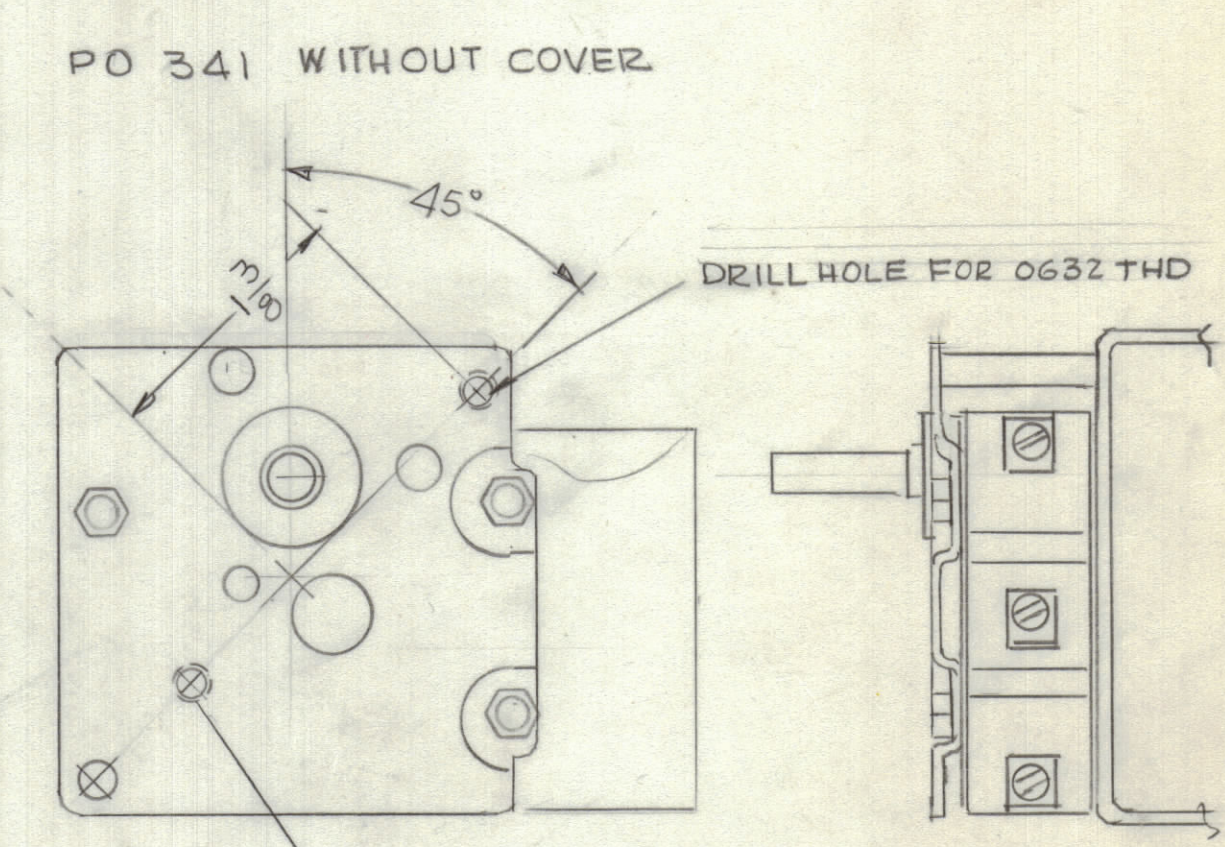
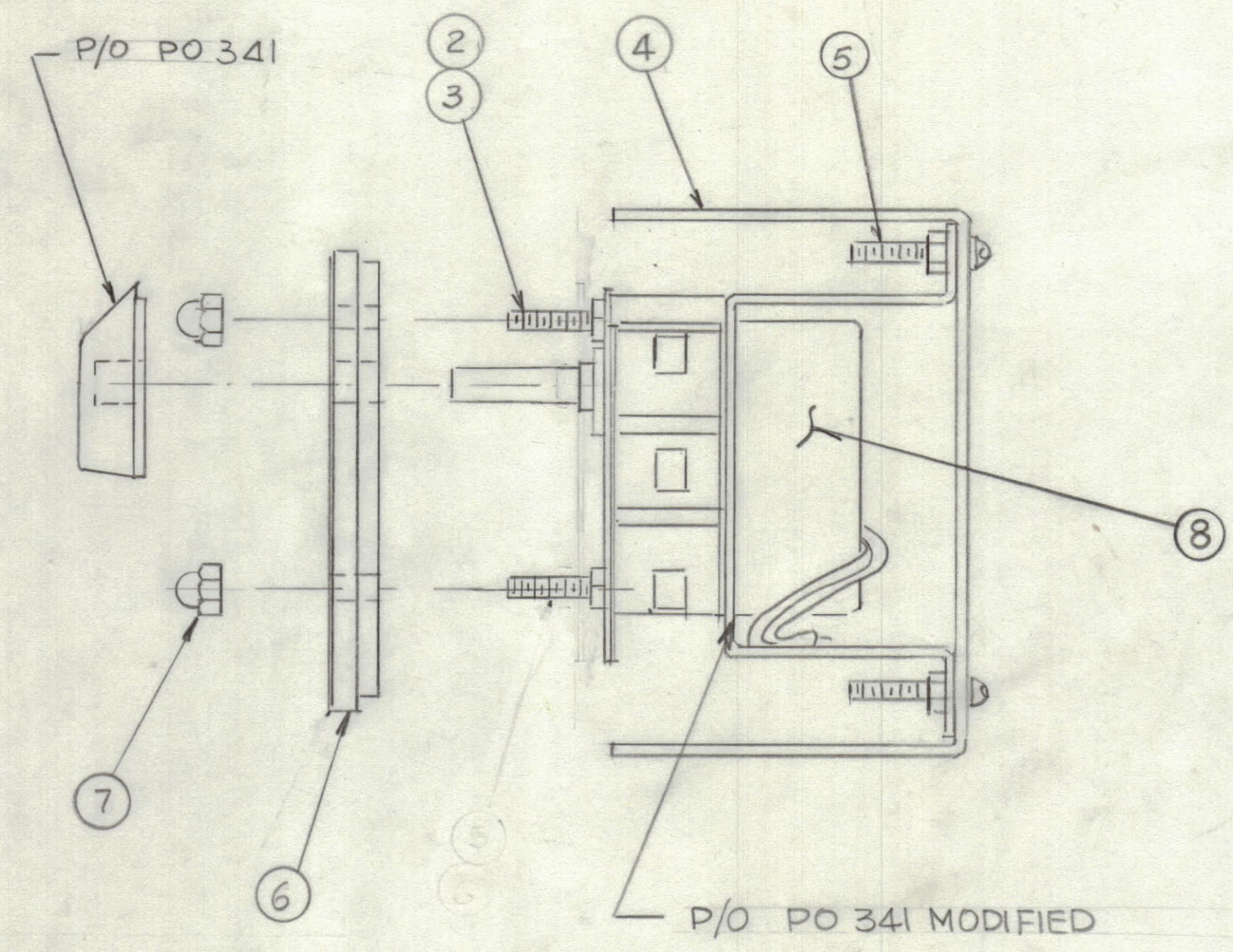
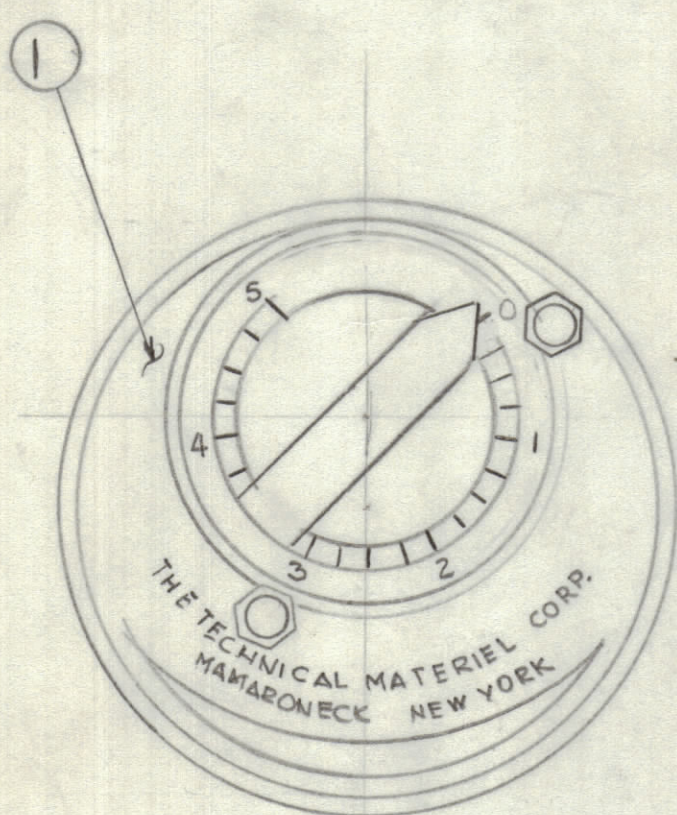

**OBsolete**  
SPARE PARTS ONLY

SEE ID452  
(INSTALLATION TI101)

PO 341 MODIFIED  
MODIFY PO341 AS SHOWN  
BEFOR ASSEMBLY

QTY. REQ.	ITEM	PART NO.	DESCRIPTION
1	1	NP1007	NAME PLATE
2	2	SM 0632 5/16 IN	STUD
4	3	NT0632-8	NUT HEX
1	4	MS 7072	BRACKET MTG.
2	5	SCBP0632BN14	SCREW MACHINE
1	6	PX1282	PLATE MTG
2	7	NTC0632BNL	NUT CAPTIVE
1	8	PO341-( )	-1 (5 MIN) -2 (60 SEC)

QTY. REQ.	ITEM	PART NO.	DESCRIPTION	SYMBOL
LIST OF MATERIAL				
THE TECHNICAL MATERIEL CORP. MAMARONECK, NEW YORK				
TIMER, ADJUSTABLE				
SIZE	CODE IDENT. NO.	DWG NO.	ISSUE	
C	82679	TI 101	G	
SCALE	SHEET			OF
1:1	1			2

GPT-10K		
QTY / UNIT	MODEL USED ON	ASS'Y NO.
APPLICATION		
CODE		
NOTICE TO PERSONS RECEIVING THIS DRAWING THE TECHNICAL MATERIEL CORPORATION claims proprietary right in the material disclosed hereon. This drawing is issued in confidence for engineering information only and may not be reproduced or used to manufacture anything shown hereon without permission from THE TECHNICAL MATERIEL CORPORATION to the user. This drawing is loaned for mutual assistance and is subject to recall at any time.		

UNLESS OTHERWISE SPECIFIED  
DIMENSIONS ARE IN INCHES  
AND INCLUDE CHEMICALLY APPLIED  
OR PLATED FINISHES

TOLERANCES ON

DECIMALS	FRACTIONS
.X ± .05	± 1/64
.XX ± .01	ANGLES
.XXX ± .005	± 0° -30'

MATERIAL

FINISH

FINAL APPROVAL	DATE
<i>[Signature]</i>	3-24-82
MECH. DES.	DATE
ELECT. DES.	DATE
CHECKED	DATE
DRAWN	DATE
E.D.L.	3-5-82