

IF IT IS FOUND DESIRABLE TO CHANGE ANY TOLERANCE OR OTHER DETAIL SPECIFIED ON THIS DRAWING NOTIFY THE PURCHASER PROMPTLY.  
 MAXIMUM ALLOWABLE TOLERANCES HAVE BEEN DETERMINED AND DEVIATIONS WILL BE CAUSE FOR REJECTION. REMOVE ALL BURRS AND SHARP EDGES

LETTERING  $\frac{1}{8}$  HIGH  
 BLACK GOTHIC  
 (SAME AS PER FIG. 2104)

HOLE DIMENSIONS

- A - NONE
- B -  $\frac{3}{16}$  (.187) DIA. X  $\frac{1}{2}$  SLOT 4 REQ
- C -  $\frac{13}{64}$  (.203) DIA 6 REQ
- D - SEE DETAIL
- E -  $\frac{7}{16}$  (.437) DIA 4 REQ
- F -  $\frac{1}{2}$  (.500) DIA 1 REQ
- G - 1 (1.000) DIA 2 REQ
- H -  $\frac{5}{8}$  (.625) DIA 2 REQ
- I -  $\frac{1}{8}$  (.125) DIA 8 REQ

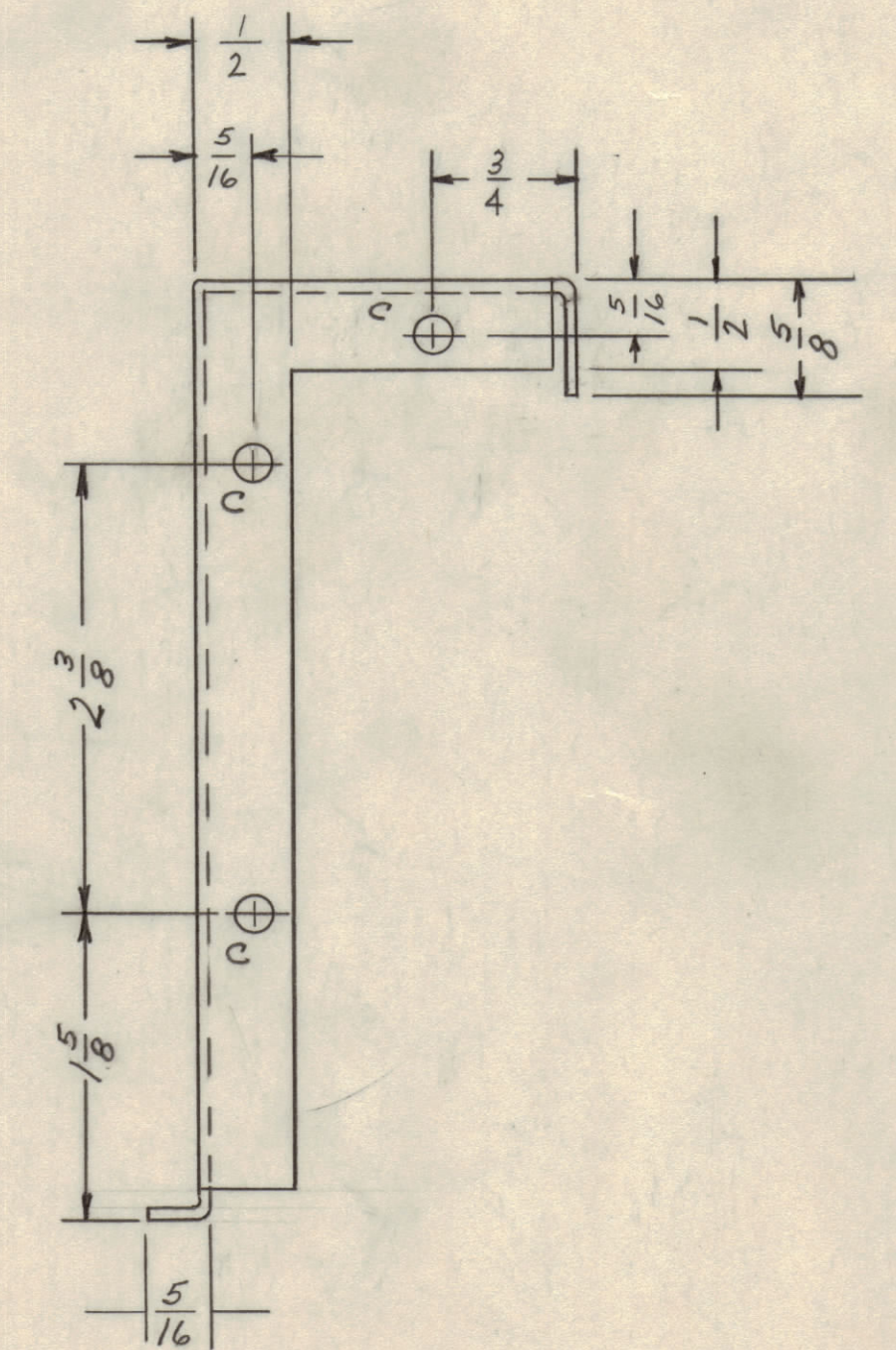
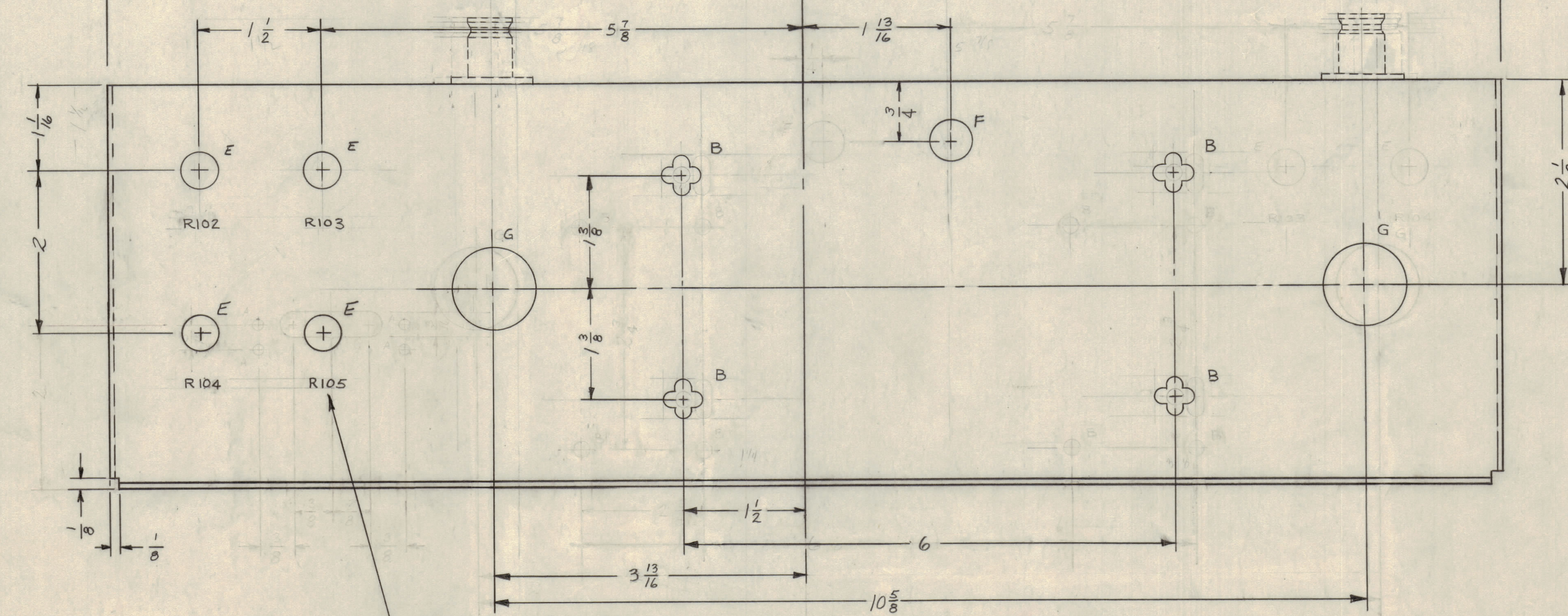
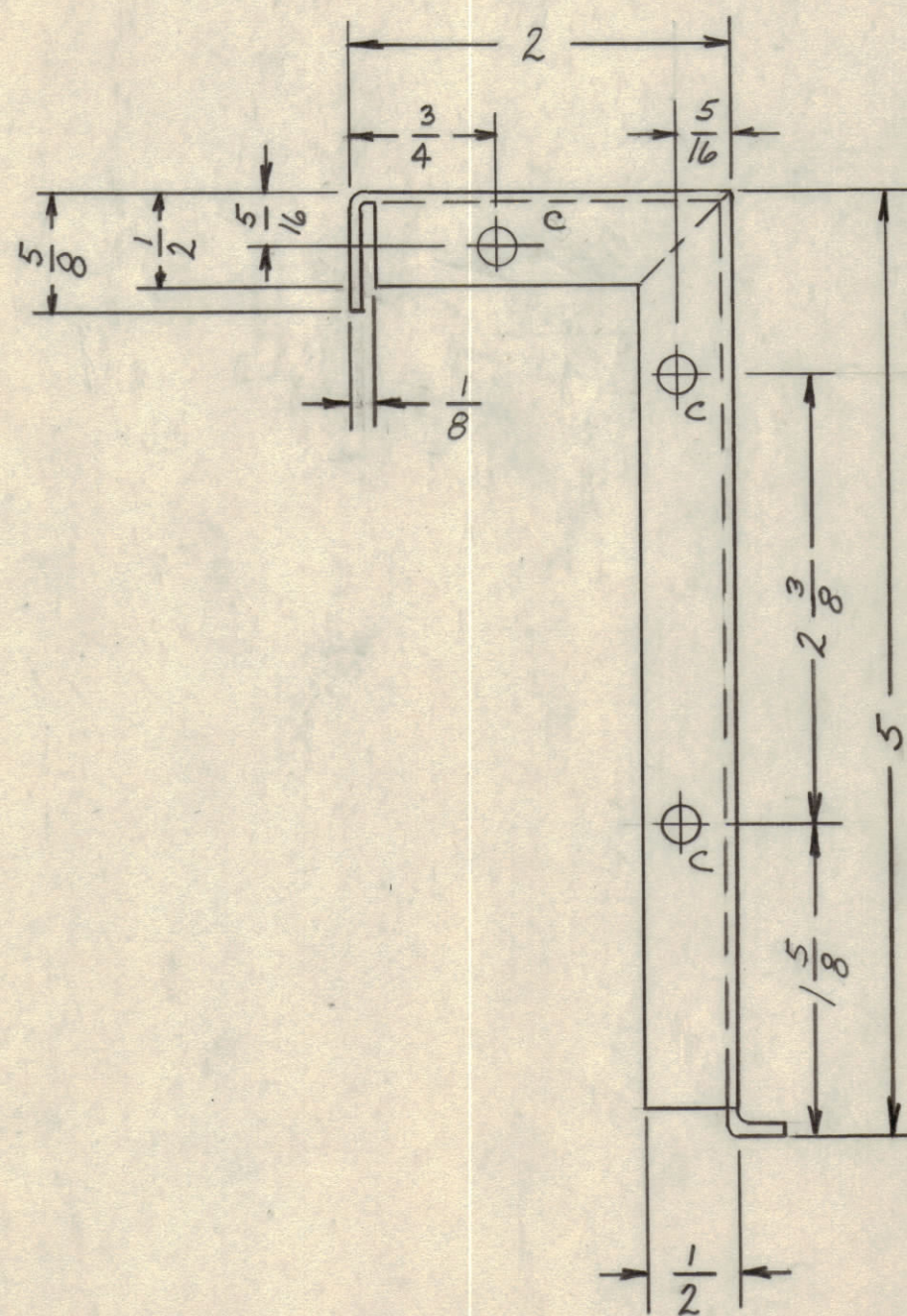
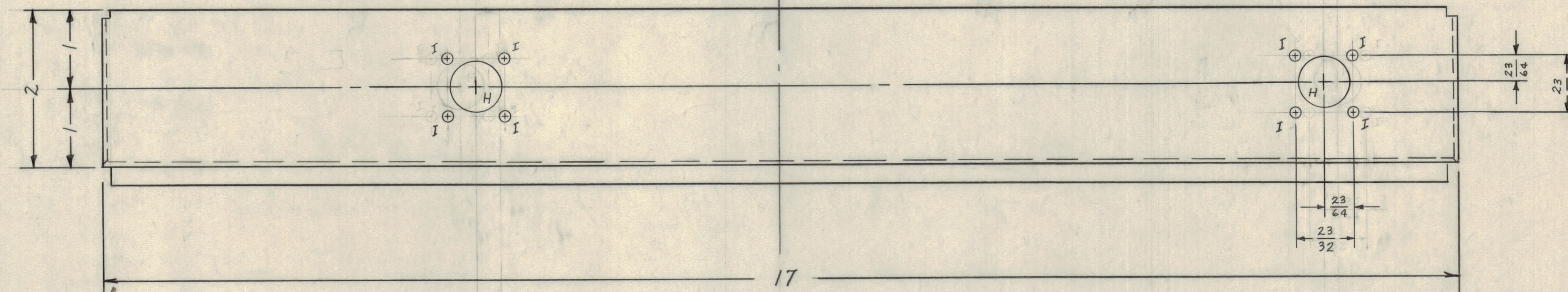
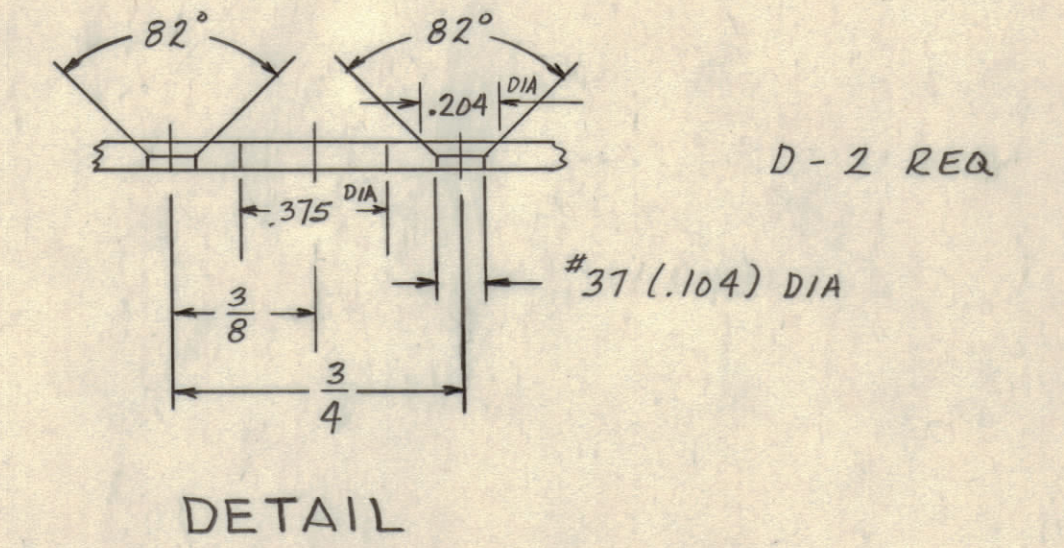
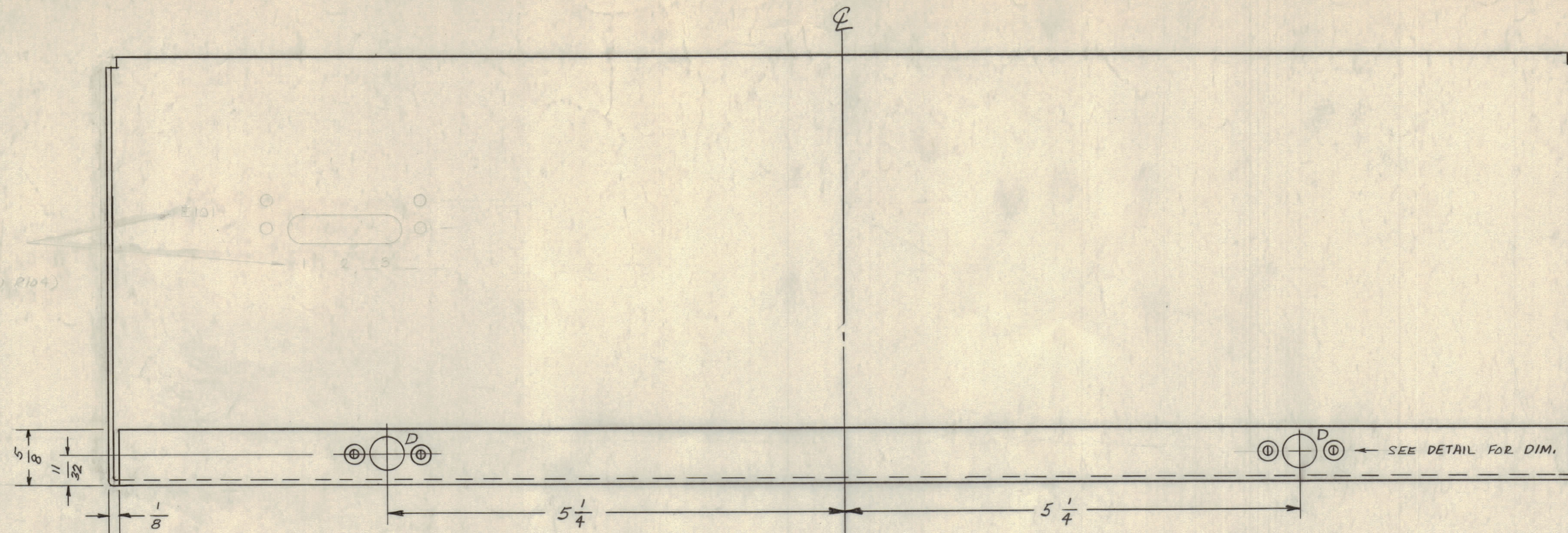

LETTERING  $\frac{1}{8}$  HIGH BLACK GOTHIC

SY-1001

ISSUE	ITEM	CHANGED FROM	DATE	CN. NO.	DRAFTS	CHECKER	ENG. APP.
TOLERANCES		SCALE:					
ALL	DEC. DIM. $\pm$	DRILL, PUNCH, COMMERCIAL STOCK					
OTHERS	FRAC. DIM. $\pm$	SIZES AND MANUFACTURERS					
	ANGULAR DIM. $\pm$	TOLERANCES ARE NOT INCLUDED.					

REQ. PER UNIT	MODEL	PROJECT NO.	ASSY. NO.	DATE

REQ. ITEM	PART NO.	DESCRIPTION	SYMBOL
	.064 THICK	THE TECHNICAL MATERIEL CORP.	
	STOCK SIZE	MAMARONECK, NEW YORK	
ALUMINUM		CHASSIS FOR SWR-1K	
MATERIAL	WEIGHT PER PC.		
5052 H 32			
TYPE & TEMPER	MIT	1-25-60	
HEAT TREAT. SPEC.	CHECKER	FINAL APPROVAL	
S-404 YEL IRIDITE			
FINISH & SPEC. NO.			