

REVISIONS						
ZONE	SYM.	DESCRIPTION	DATE	E.M.N. NO.	DRAFT	CHKD
B7/BAC2/D2 C2, A7	A	NOTES, CHART, ITEM (1) ADDED; ITEM (2) QTY WAS 16, DIMS CLARIFIED ITEM (8) WAS "SEE NAMEPLATE NOTE", NAMEPLATE NOTE DELETED	3-21-63	8498	RC	WAB

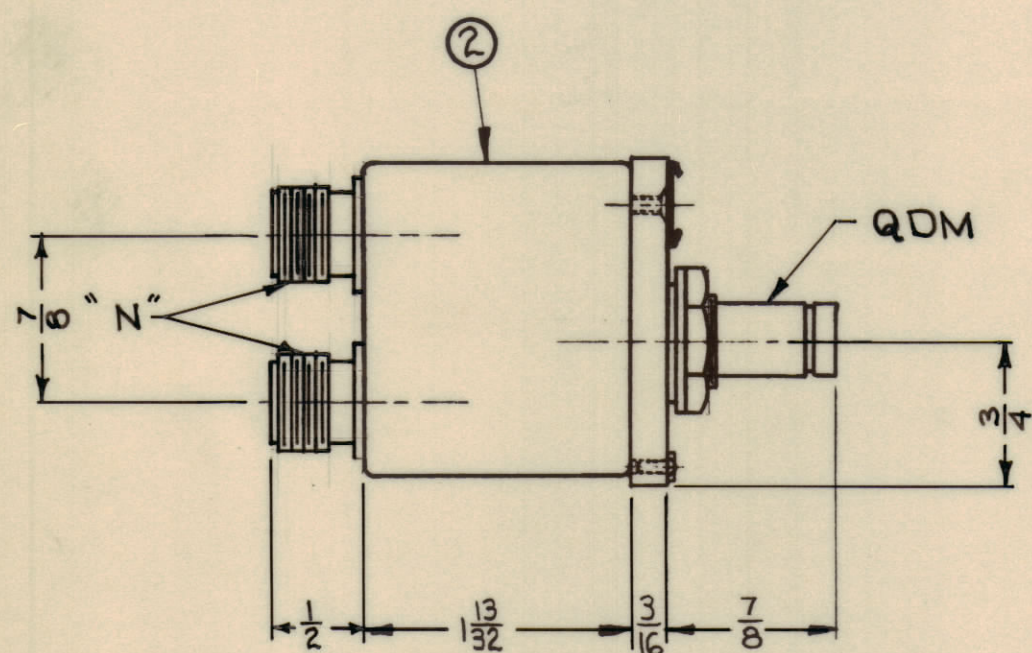
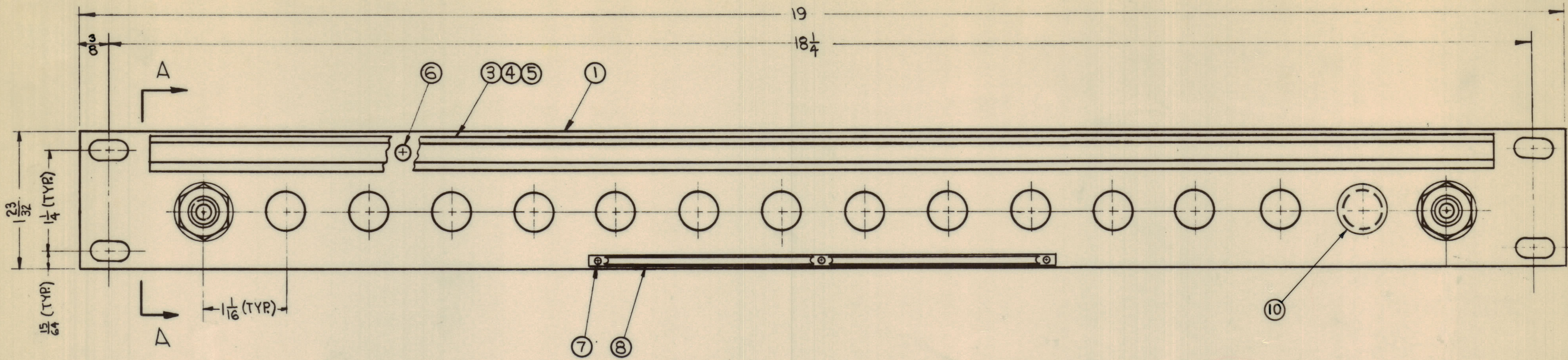

SIDE VIEW A-A

NOTES:

1. SWITCHES (ITEM 2) ARE MOUNTED FROM LEFT TO RIGHT.
2. WHEN SWITCH MOUNTING HOLES ARE NOT UTILIZED, PLUG BUTTONS (ITEM 10) ARE MOUNTED ON FACE OF PANEL.
3. REFER TO CHART FOR APPLICATION OF PLUG BUTTONS (ITEM 10) WHEN REQUIRED.

SPP-30616	16	0
SPP-30615	15	1
SPP-30614	14	2
SPP-30613	13	3
SPP-30612	12	4
SPP-30611	11	5
SPP-30610	10	6
SPP-3069	9	7
SPP-3068	8	8
SPP-3067	7	9
SPP-3066	6	10
SPP-3065	5	11
SPP-3064	4	12
SPP-3063	3	13
SPP-3062	2	14
SPP-3061	1	15
MODEL	QUANTITY ITEM 2	QUANTITY ITEM 10

SEE CHART	ITEM	PART NUMBER	DESCRIPTION	SYMBOL
10		HB-101-11-G	PLUG, BUTTON	
X	9	S-692	TEST PROCEDURE	
1	8	NP-251	NAMEPLATE IDENTIFICATION	
3	7	SFBP0256SN3	SCREW, THREAD CUTTING	
6	6	SCFP0348BN3	SCREW, MACHINE	
1	5	PX-396-17	GUARD, TAB	
1	4	PR-101-17	TAP, PAPER	
1	3	MS-1184	HOLDER, CARD	
2		SW-307	SWITCH, JACK ASSEMBLY	
1	1	MS-2973	MACHINING, FRONT PANEL	

LIST OF MATERIAL

MATERIAL	ALUMINUM 19x3 1/32 x 3/16	THE TECHNICAL MATERIEL CORP. MAMARONECK, NEW YORK		
FINISH	SI15 TMC SMOOTH GREY ENAMEL	TITLE PANEL, PATCH R.F. SWITCHING		
UNLESS OTHERWISE SPECIFIED DIMENSIONS ARE IN INCHES AND INCLUDE CHEMICALLY APPLIED OR PLATED FINISHES		DRAWN	DATE	FINAL APPROVAL
DECIMALS .X ± .05 .XX ± .01 .XXX ± .005		CHECKED	DATE	DATE
TOLERANCES FRACTIONS ± 1/64 ANGLES ± 0° 30'		ELECT. DES.	DATE	DATE
		MECH. DES.	DATE	DATE

Q'TY./UNIT	MODEL USED ON	ASS'Y. NO.
DO NOT SCALE	SEE CHART	
THE CONTENTS OF THIS DRAWING ARE THE EXCLUSIVE PROPERTY OF THE TECHNICAL MATERIEL CORP. ITS UNAUTHORIZED USE OR REPRODUCTION IN WHOLE OR IN PART IS STRICTLY FORBIDDEN.		

NOTES

SPP-30616 A