

TMC P/N	A	B	C	D	E	F	FINISH	REQ. PER UNIT	USED ON				
									MODEL	ASS'Y. NO.	DATE		
SC165-1	.875	.312	.065-.070	3/8	.180	6-32	5245 SILVER PL.	9	RFTA-1		12-18-64	SC165	E
-2	1.125	"	"	"	"	"	"	5					
-3	.9375	"	"	"	"	"	"						
-4	1.562	.625	.187	3/4	.248	10-32	"						
-5	1.562	.625	.187	7/16	.248	10-32	"						
-6	1/2	7/16	3/16	1/2	.248	10-32	"						
-7	1-1/8	15/16	3/16	7/16	.248	1/4-20	"						

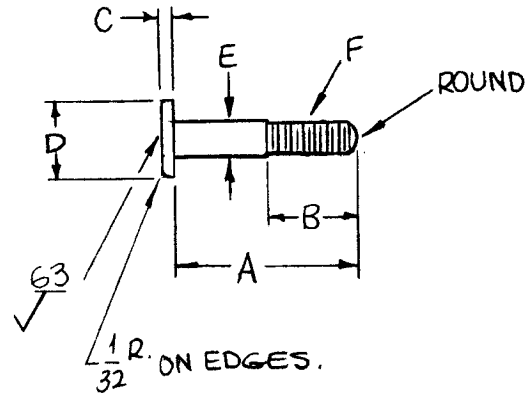

E	ADD - 7 P/N CHART	12/22/68	19690	KH	MR	FB	
D	ADDED - 6 P/N CHT	8-11-68	19525	GE	MR	FB	
C	ADDED - 4 - 5 P/N CHT	5/26/69	19419	GE	MR	EFM	
B	ADDED SC165-3	6-19-68	18961	HY	MR	FB	
A	- DIM 'A' WAS 1.0 "A" DIM CHG TO REFLECT CHT-1	11/18/66	17245	LHW	MR	FB	
Ø	ORIGINAL RELEASE	10/18/66	Ø				
X ₁	ON SC165-1 'A' WAS .945; 'B' W. .250 SC165-2 ADDED	3.10.65	X ₁	MR			
X	EXP. RELEASE	12-18-64	X	SRG			
SYM	DESCRIPTION	DATE	CH. NO.	DRAFTS	CHECKER	ENG. APP.	
UNLESS OTHERWISE SPECIFIED DIMENSIONS ARE IN INCHES AND INCLUDE CHEMICALLY APPLIED OR PLATED FINISHES		SCALE	---				
DECIMALS .X ± .05 .XX ± .01 .XXX ± .005	TOLERANCES	FRACTIONS ± 1/64 ANGLES ± 0° 30'	CODE A				

REQ. ITEM	PART NO.	F. BUDETTI	DESCRIPTION	SYMBOL
			THE TECHNICAL MATERIEL CORP. MAMARONECK, NEW YORK	
			CONTACT, BOTTOM	
			BRASS	
			MATERIAL	
		SRG	DRAWN	
			CHECKED	
			FINAL APPROVAL	
			SEE CHART	
			FINISH & SPEC. NO.	
			ELEC. DES. APP.	
			MECH. DES. APP.	
			SC165	E