

REQ. PER UNIT	USED ON		
	MODEL	ASSY. NO.	DATE
7	RTX-2		9-17-58
2	GPT-101K	AX-103	1-24-59

SC-139 C

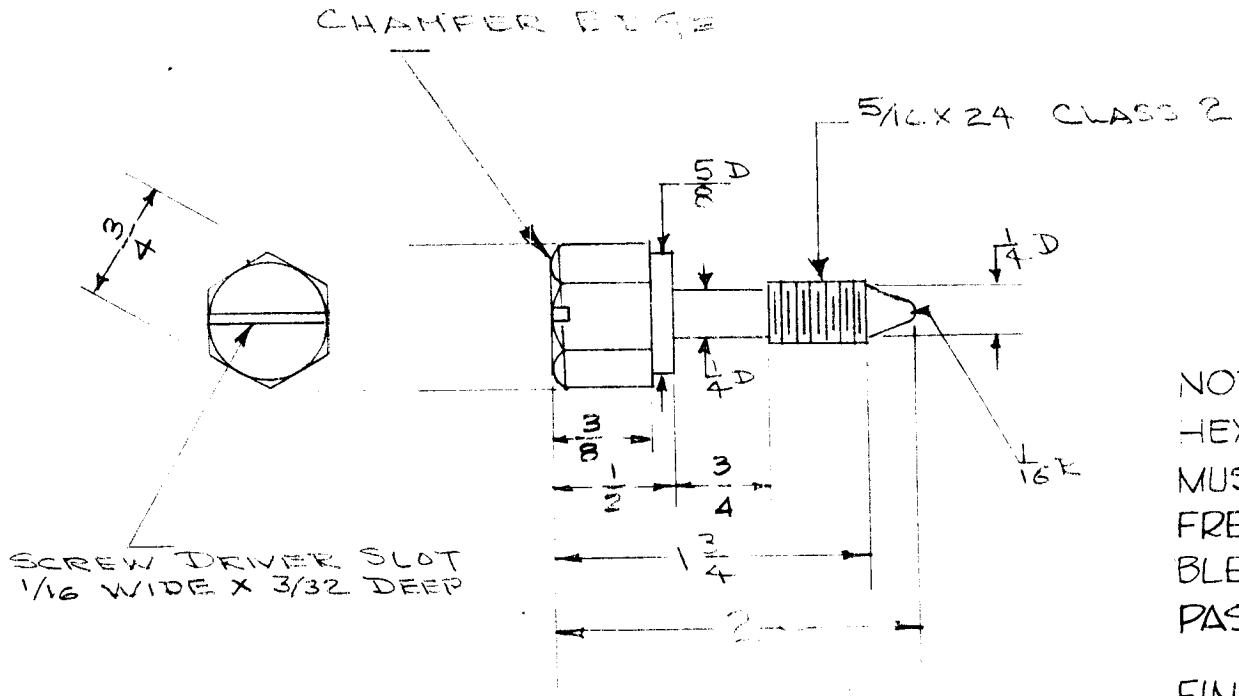

NOTE -
HEXHEAD AND SHAFT
MUST BE SMOOTH AND
FREE OF ALL MACHINING
BLEMISH MARKS BEFORE
PASSIVATING.

FINISH -
S104-PASSIVATE.

MAKES WITH NT-124

ISSUE	ITEM	CHANGED FROM	DATE	CH. NO.	DRAFTS	CHECKER	ENG. APP.
C	1	Notes Added	7/24/61	5336	JCB	JCB	JCB
B	1	3/4 DIM WAS 5/8	6/4/59	1105	JCB	JCB	JCB
A	1	3/4 FLATS WAS 1" 3/8 HD. THE WAS 1/2 3/8 B/A HD. WAS 5/8	9/25/58	1	16	JCB	JCB

TOLERANCES

SCALE: $\frac{1}{2}$

DEC. DIM. \pm
FRAC. DIM. \pm 1/64
ANGULAR DIM. \pm

MAXIMUM ALLOWABLE TOLERANCES HAVE BEEN DETERMINED AND ANY DEVIATIONS WILL BE CAUSE FOR REJECTION.
REMOVE ALL BURRS AND SHARP EDGES

REQ. ITEM	PART NO.	DESCRIPTION	SYMBOL
		THE TECHNICAL MATERIEL CORP. MAMARONECK. NEW YORK	
	STOCK SIZE	HEXAGON, THUMB SCREW	
	MATERIAL	STAINLESS STEEL	
103		JCB	16
	TYPE & TEMPER	HEAT TREAT. SPEC.	DRAWN
			CHECKED
	FINISH & SPEC. NO.	ELEC. DES. APP.	MECH. DES. APP.
		JCB	SC-139
			C