

IF IT IS FOUND DESIRABLE TO CHANGE ANY TOLERANCE OR OTHER DETAIL SPECIFIED ON THIS DRAWING NOTIFY THE PURCHASER PROMPTLY.

SC-101

MAXIMUM ALLOWABLE TOLERANCES HAVE BEEN DETERMINED AND DEVIATIONS WILL BE CAUSE FOR REJECTION. REMOVE ALL BURRS AND SHARP EDGES

USED ON

MODEL	PROJECT NO.	ASS'Y. NO.	DATE
RAC	112	A-101	7-8-52
BAC-3-S-20	108	A-108	7-9-52
BAC-2-S-20	108	A-107	7-9-52
BAC-3-S-500	153	A-135	9-6-52
KS-85-X	J-227	A-498	12/2/54

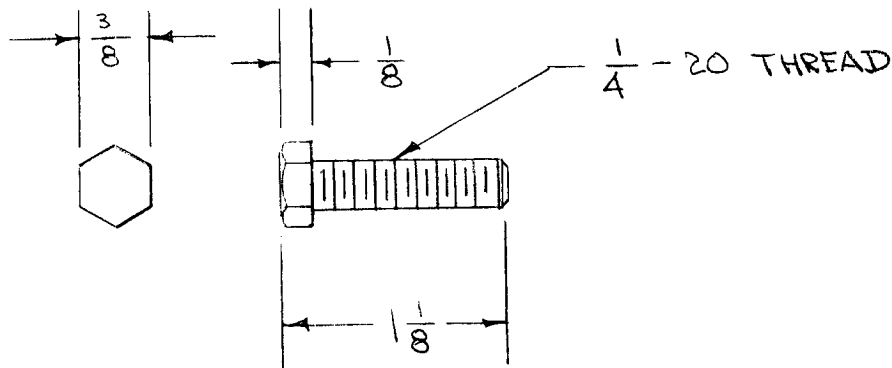

REQ.	ITEM	PART NO.	DESCRIPTION	SYMBOL
		//	THE TECHNICAL MATERIEL CORP. MAMARONECK. NEW YORK	
		STOCK SIZE		
		STEEL	BOLT, HEX HEAD	
		MATERIAL		
		WEIGHT PER PC.		
		//		
		TYPE & TEMPER	C.D.D. 2-12-54	WDE
			DRAWN	ELEC. DES. APP. MECH. DES. APP.
		//	WDE	WDE
		HEAT TREAT. SPEC.	CHECKED	FINAL APPROVAL
		S-105 CADMIUM PLATE		SC-101
		FINISH & SPEC. NO.		

ISSUE	ITEM	CHANGED FROM	DATE	CN. NO.	DRAFTS	CHECKER	ENG. APP.
		REDRAWN, NO CHANGE.				WDE	WDE

TOLERANCES		SCALE	
ALL OTHERS	DEC. DIM. ± FRAC. DIM. ± ANGULAR DIM. ±	DRILL, PUNCH, COMMERCIAL STOCK SIZES AND MANUFACTURERS TOLERANCES ARE NOT INCLUDED.	