

DATE 18/11/59

H. 1 OF 7

COMPILED BY  
N.K.

**TMC SPECIFICATION NO. S - 10027**

**TITLE:** PRODUCTION TESTING OF MODEL PCA-2

**JOB**

APPROVED

*M. W.*

*1 Spec.*

INSTRUCTIONS FOR THE

PRODUCTION TESTING

OF THE

MODEL PCA-2

DATE 18/11/59

SH. 2 OF 7

COMPILED BY  
N.K.

# TMC SPECIFICATION NO. S - 10027

TITLE: PRODUCTION TESTING OF MODEL PCA-2

JOB

APPROVED

*N.K.*

*P.C.*

## I N D E X

	<u>PAGE</u>
1. Test Equipment required	3
2. Test Instructions	3
3. General Instrument Layout	4
4. Test Sequence and Procedure	5
A. General and Visual Inspection	5
B. Gain Test	5
C. Frequency Response	6
D. Noise Test	6
E. Distortion Measurement	7
F. Clip Level Control Adjustment	7

DATE 18/11/59

SH. 3 OF 7

COMPILED BY

N.K.

TMC SPECIFICATION NO. S - 10027

TITLE: PRODUCTION TESTING OF MODEL PCA-2

JOB

APPROVED

*u. kr*

*JG*

1. TEST EQUIPMENT REQUIRED

1. Oscilloscope
2. Audio Frequency Oscillator, Hewlett-Packard Model 200C or equivalent.
3. High Impedance AC Voltmeter HP 410B or equivalent.
4. Distortion Analyser Hewlett-Packard Model 330B or equivalent.
5. Audio Amplifier, maximum distortion 0.1%.
6. Two Isolation Transformers 1/1 ratio Hammond 804 or equivalent nt.

2. TEST INSTRUCTIONS

Proceed as outlined in paragraph 4, Test Sequence and Procedure.

DATE 18/11/59  
SH. 4 OF 7  
COMPILED BY  
N.K.

# TMC SPECIFICATION NO. S-10027

TITLE: PRODUCTION TESTING OF MODEL PCA-2

JOB

APPROVED

*M. Ker.*

*D. Lee.*

### 3. GENERAL INSTRUMENT LAYOUT

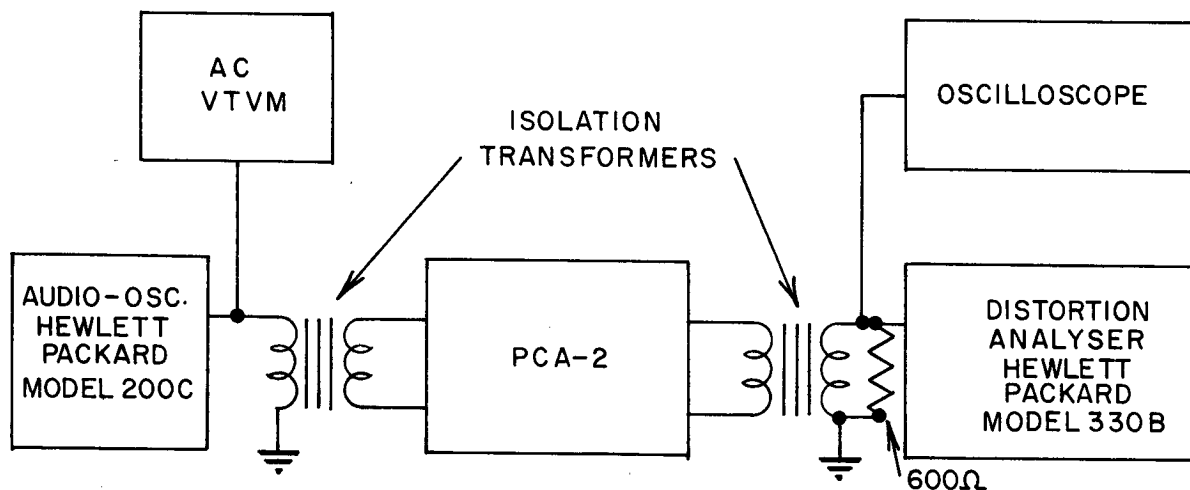

FIGURE I

This block diagram is valid for all tests of paragraph 4A to 4D inclusive and 4F.

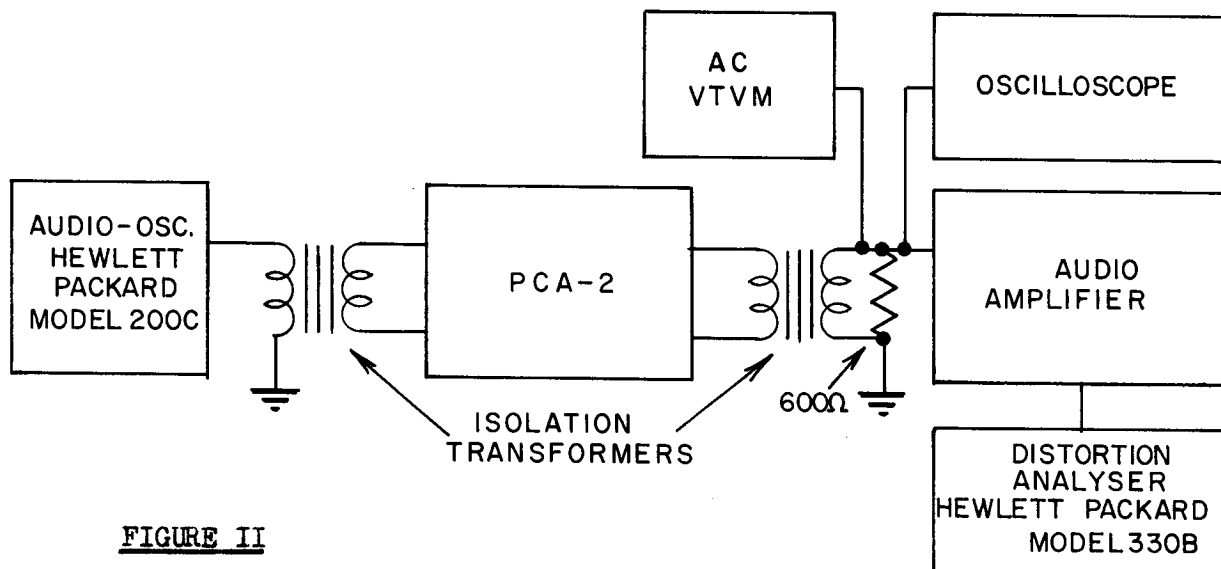

FIGURE II

This block diagram is valid for test described in paragraph 4E only.

DATE 18/11/59

SH. 5 OF 7

COMPILED BY  
N.K.

# TMC SPECIFICATION NO. S - 10027

TITLE: PRODUCTION TESTING OF MODEL PCA-2

JOB

APPROVED

*M. Ke...*

*leg*

## 4. TEST SEQUENCE AND PROCEDURE

### A. GENERAL AND VISUAL INSPECTION

1. Inspect the unit for obvious mechanical and electrical errors.
2. Check that all screws are tight.

### B. GAIN TEST

1. Connect equipment in accordance with Fig. 1.
2. Turn clip level potentiometer R111 fully clockwise for minimum clipping.
3. Turn attenuator R128 fully clockwise for minimum attenuation.
4. Turn output of audio oscillator to minimum output.
5. Switch power of PCA-2 on and allow a warm up time of approximately one minute.
6. Set the oscillator to 4000 c/s.
7. Switch the gain switch SW101 to 20db gain.
8. Turn oscillator output up until the output level of the PCA-2 is 0-db. The input level should now read  $-20 \pm 3$ db.
9. Switch the gain switch SW101 to 50db gain.
10. Set the attenuator R128 to 15db attenuation.
11. Turn oscillator output up until the output level of the PCA-2 is 0-db. The input level should now read  $-35 \pm 4$ db.
12. Set the attenuator R128 to 43,5db attenuation.
13. Switch the gain switch SW101 to 80db gain.
14. Turn the oscillator output up until the output level of the PCA-2 is 0-db.
15. The input level should now read  $-36.5 \pm 6$ db.

DATE 18/11/59

SH. 6 OF 7

COMPILED BY  
N.K.

# TMC SPECIFICATION NO. S - 10027

TITLE: PRODUCTION TESTING OF MODEL PCA-2

JOB

APPROVED

*M. Ver.*

*18/11/59*

## C. FREQUENCY RESPONSE

1. Switch gain switch SW101 to 50db.
2. Set oscillator to 4000 c/s and adjust PCA-2 output to 0-db.
3. Set the oscillator to the below mentioned frequencies and record the gain deviation from 0-db.

A typical frequency response is shown below:

200 c/s	-19db
400 c/s	-10db
800 c/s	-6.5 db
1600 c/s	-3.5db
3200 c/s	+ 1db
4000 c/s	0-db
10000 c/s	-27db

Figures obtained to be within  $\pm$  2db of figures above.

## D. NOISE TEST

1. Switch gain switch to 50db gain.
2. Set attenuator R128 of PCA-2 at 0-db.
3. Set oscillator at 4000 c/s.
4. Turn output of oscillator up until the output level of the PCA-2 reads 0-db.
5. Turn output of oscillator fully down.
6. Output level of PCA-2 should be less than - 45db.

DATE 18/11/59

H. 7 OF 7

COMPILED BY  
N.K.

# TMC SPECIFICATION NO. S- 10027

TITLE: PRODUCTION TESTING OF MODEL PCA-2

JOB

APPR VED *M. K.*

*Joe*

## E. DISTORTION MEASUREMENT

1. Arrange test set-up as shown in Figure 2.  
The amplifier has to be used when using Hewlett-Packard Distortion Analyser Model 330B as the output level of the PCA-2 OVU is insufficient to permit setting level for distortion.
2. Set the attenuator R128 to 0-db.
3. Switch gain switch to 50db gain.
4. Adjust the clip level control for minimum clipping (fully clockwise)
5. Set the oscillator frequency at 4000 c/s and adjust the oscillator output for 0-db at the PCA-2 output.
6. Measure distortion.
7. Total distortion to be less than 1.0%.

## F. CLIP LEVEL CONTROL ADJUSTMENT

1. Connect equipment in accordance with figure 1.
2. Turn the clip level control R111 to its maximum clockwise position (position of least clipping).
3. Throw Output Unclipped Meter switch to the Output position.
4. Set the oscillator-frequency to 400 c/s.
5. Set the attenuator R128 to 11.5db.
6. Adjust the oscillator output to obtain a 0 VU reading on the meter. (The output level should now be 0-db.)
7. Adjust the attenuator R128 until the VU-meter reads approximately -4VU.
8. Turn the clip lev 1 control R111 anti-clockwise until you observ a slight clipping of th peaks of the output wav . Tighten the locknut of R111. Check that increasing driv lev 1 will not rais the output lev 1 above + 2 VU.