

REQ. PER UNIT	USED ON			RY154 Ø
	MODEL	ASS'Y. NO.	DATE	
	HFR-2A	A3624	5-6-64	
	HFRR-2	A3625	9-11-64	

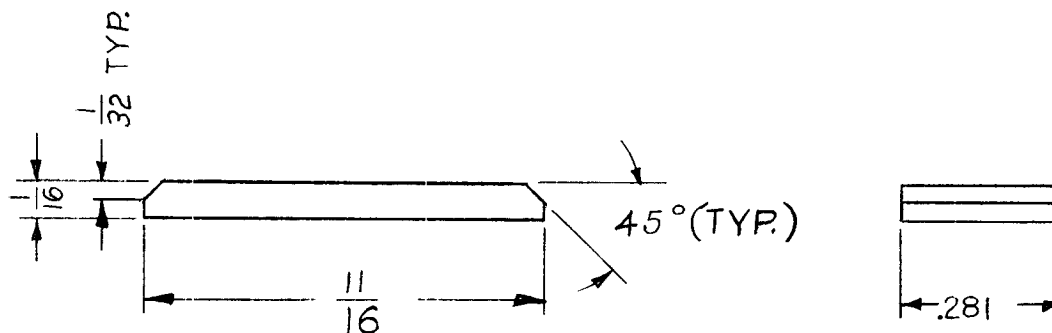

NOTE:

REMOVE ALL BURRS & SHARP EDGES

SYM	DESCRIPTION	DATE	CH. NO.	DRAFTS	CHECKER	ENG. APP.	REQ. ITEM	PART NO.	T. KRUY	DESCRIPTION	SYMBOL
Ø	ORIGINAL RELEASE FOR PRODUCTION	9.11.64	Ø	Y.L.				1/16 THK		THE TECHNICAL MATERIEL CORP. MAMARONECK, NEW YORK	
X <sub>1</sub>	TITLE WAS STRIP, NEOPRENE	9.10.64	X <sub>1</sub>	Y.L.				STOCK SIZE			
X	EXPERIMENTAL RELEASE	5/6/64	X	AM.				NEOPRENE			
										RUBBER STRIP-LOCK	
UNLESS OTHERWISE SPECIFIED DIMENSIONS ARE IN INCHES AND INCLUDE CHEMICALLY APPLIED OR PLATED FINISHES		SCALE		11			60 DUROMETER		A. MARINO	@	R/L
DECIMALS .X ± .05 .XX ± .01 .XXX ± .005		FRACTIONS ± 1/64 ANGLES ± 0° 30'		TOLERANCES			TYPE & TEMPER	HEAT TREAT. SPEC.	DRAWN	CHECKED	FINAL APPROVAL
							BLACK			T. Kruey	RY154 Ø
							FINISH & SPEC. NO.		ELEC. DES. APP.	MECH. DES. APP.	