

TMC P/N	X	Y	Z
PX1018	N/A	N/A	N/A
PX1018-2	2-1/2	3/16	1-23/64

REVISIONS						
ZONE	LTR	DESCRIPTION	DATE	E.M.N.NO	DRAFT	CHKD APPD
	X	EXP. RELEASE	10/9/67		H.G.	<i>[Signature]</i>
	Ø	ORIGINAL RELEASE FOR PRODUCTION	4/2/68	Ø	<i>[Signature]</i>	<i>[Signature]</i>
	A	ITEM 1 WAS NT129-SF1-20	8-1-68	19016	<i>[Signature]</i>	FB
	B	P/N CHAET & NOTCH ADD	11/21/70	19726	<i>[Signature]</i>	FB
	C	CLERICAL CHG	4/4/70	N	KD	<i>[Signature]</i>
	D	ADD (1032) TO IT. 1 DES.	6-21-73	20753	GE	<i>[Signature]</i>

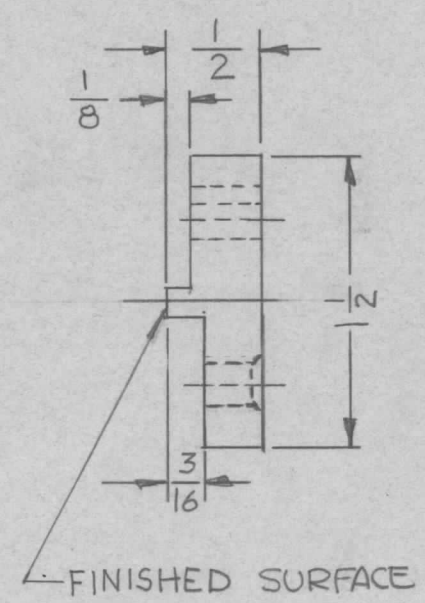
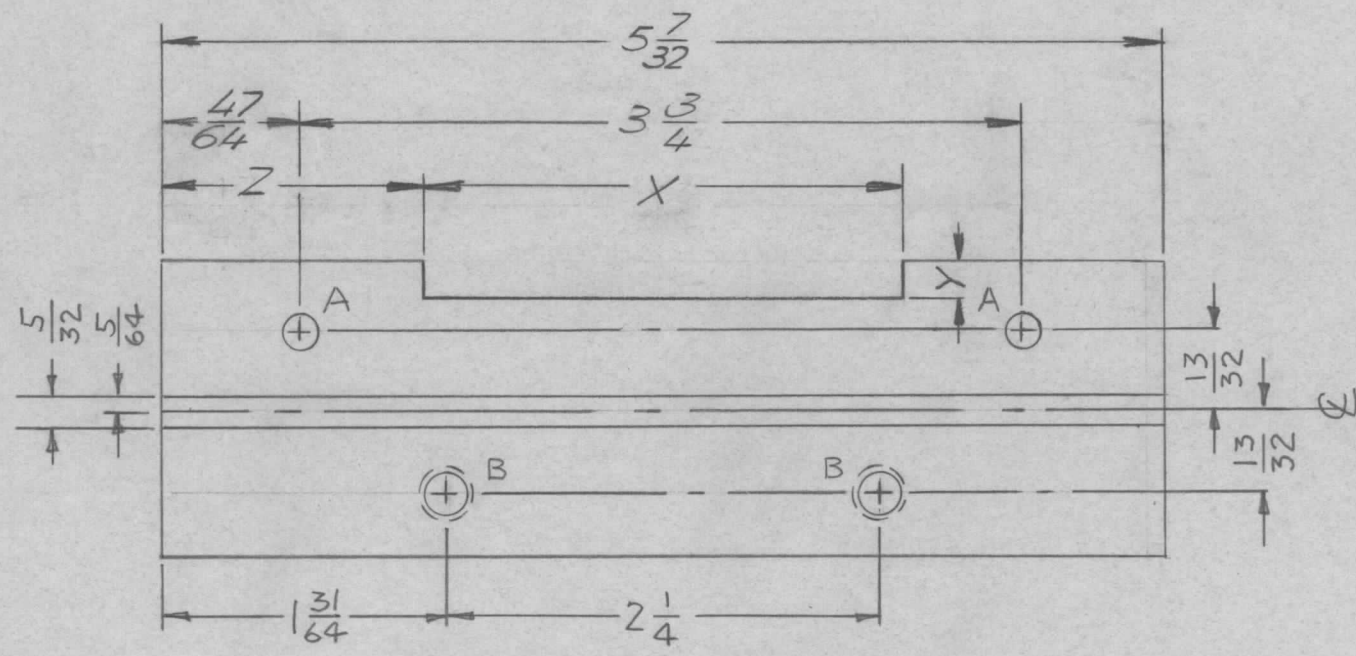

HOLE	DESCRIPTION	REQ.
A	11/64 DIA.	2
B	SEE NOTES	2

- "B" HOLE NOTES
- 1- DRILL 13/64 (.203) THRU.
  - 2- 120° COUNTERSINK .22-.25 DIA.
  - 3- TAP THRU. USE HELI-COIL TAP
  - 4- INSTALL ITEM 1.
  - 5- BREAK OFF DRIVING TANG.

2	1	NT 139-SF1-20	SCREW, THREAD INSERT (1032)	B
REQ'D	ITEM	PART NUMBER	DESCRIPTION	SYM.
BUDETTI			LIST OF MATERIAL	SK 3290-PX2001

1 EA.	BCT-10KA	
QTY / UNIT	MODEL USED ON	ASS'Y NO.
APPLICATION		
	CODE A	5401-451
NOTICE TO PERSONS RECEIVING THIS DRAWING THE TECHNICAL MATERIEL CORPORATION claims proprietary right in the material disclosed hereon. This drawing is issued in confidence for engineering information only and may not be reproduced or used to manufacture anything shown hereon without permission from THE TECHNICAL MATERIEL CORPORATION to the user. This drawing is loaned for mutual assistance and is subject to recall at any time.		

UNLESS OTHERWISE SPECIFIED DIMENSIONS ARE IN INCHES AND INCLUDE CHEMICALLY APPLIED OR PLATED FINISHES	FINAL APPROVAL <i>[Signature]</i>	DATE 4-7-68
DECIMALS .X ± .05 .XX ± .01 .XXX ± .005	MECH. DES. <i>[Signature]</i>	DATE 4-2-68
FRACTIONS 1/64	ELECT. DES.	DATE
TOLS. ANGLES 0°-30'	CHECKED <i>[Signature]</i>	DATE 4-2-68
MATERIAL PHENOLIC (PAPER BASE) XXXP	DRAWN H.G.	DATE 10-9-67
FINISH BLACK		
S113 FUNGUS PROOF		

THE TECHNICAL MATERIEL CORP. MAMARONECK, NEW YORK			
STRIP, INSULATOR			
SIZE B	CODE IDENT. NO. 82679	DWG NO. PX1018	ISSUE ①
SCALE 1:1	SHEET OF		