

APPLICATION			REVISIONS						
QTY	MODEL USED ON	ASS'Y NO.	LTR	DESCRIPTION	DATE	E.M.N.NO	DRAFT	CHKD	APPD
1	TRO-47A		X	EXPERIMENTAL RELEASE	2.21.67	---	LFD	SG	LB
			Ø	ORIGINAL RELEASE	8/26/69	Ø	CU.		

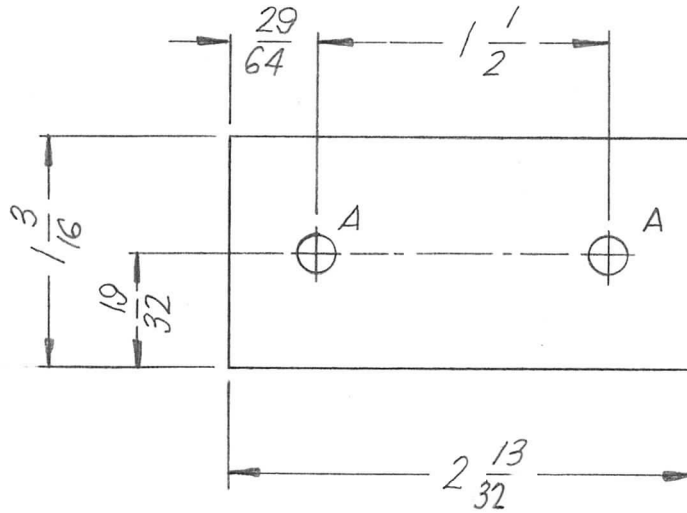

~ HOLE ~
A - 3/16 DIA (2 REQ)

NOTE:
MAT'L: 1/8 PHENOLIC, XXXP
(LINEN BASE)

UNLESS OTHERWISE SPECIFIED DIMENSIONS ARE IN INCHES AND INCLUDE CHEMICALLY APPLIED OR PLATED FINISHES		REQ'D	ITEM	PART NUMBER	DESCRIPTION	SYM.
DECIMALS: .X ± .05, .XX ± .01, .XXX ± .005; FRACTIONS: 1/64, ANGLES: 0°-30'		L. BUTLER		LIST OF MATERIAL		
MATERIAL: SEE NOTE		FINAL APPROVAL	DATE	THE TECHNICAL MATERIEL CORP.		
FINISH: S113 FUNGUS PROOF S401-451		MECH. DES.	DATE	MAMARONECK, NEW YORK		
		ELECT. DES.	DATE	PLATE, TIEDOWN		
		CHECKED	DATE			
		DRAWN	DATE			
NOTICE TO PERSONS RECEIVING THIS DRAWING: THE TECHNICAL MATERIEL CORPORATION claims proprietary right in the material disclosed hereon. This drawing is issued in confidence for engineering information only and may not be reproduced or used to manufacture anything shown hereon without permission from THE TECHNICAL MATERIEL CORPORATION to the user. This drawing is loaned for mutual assistance and is subject to recall at any time.				SIZE	CODE IDENT. NO.	DWG NO.
				A	82679	PX1014
				SCALE 1:1	SHEET OF	