

REQ. PER UNIT	USED ON			PX1002	Ø
	MODEL	ASS'Y. NO.	DATE		
2	KIT-246		11-11-66		
2	KIT-247		11-11-66		

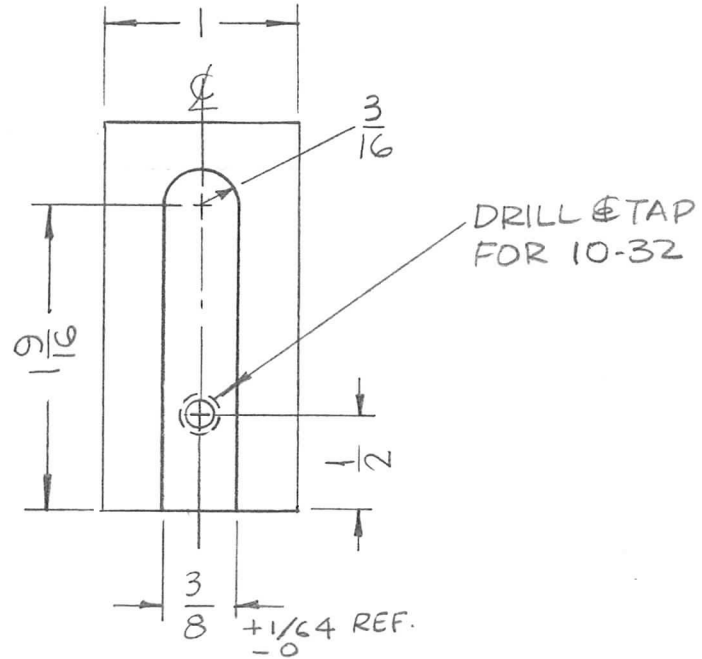
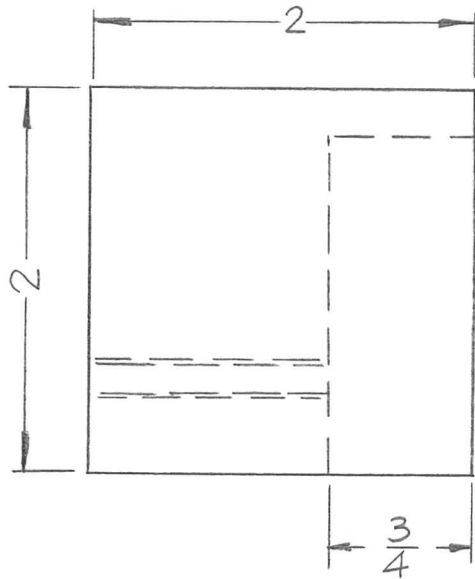

SYM	DESCRIPTION	DATE	CH. NO.	DRAFTS	CHECKER	ENG. APP.	REQ. ITEM	PART NO.	F. BUDETTI DESCRIPTION	SYMBOL	
Ø	ORIGINAL RELEASE FOR PRODUCTION	11-18-66	Ø	RME			AS SHOWN		THE TECHNICAL MATERIEL CORP. MAMARONECK, NEW YORK		
X	EXP RELEASE	11-14-66					STOCK SIZE		BLOCK, MTG SHIELD		
							PHENOLIC				
							MATERIAL				
							XXXP				
							TYPE & TEMPER	HEAT TREAT. SPEC.	DRAWN	CHECKED	FINAL APPROVAL
							S113-FUNGUS PROOF				
							FINISH & SPEC. NO.	ELEC. DES. APP.	MECH. DES. APP.	PX1002	Ø

UNLESS OTHERWISE SPECIFIED
DIMENSIONS ARE IN INCHES AND INCLUDE
CHEMICALLY APPLIED OR PLATED FINISHES

SCALE
1:1

DECIMALS
.X ± .05
.XX ± .01
.XXX ± .005

TOLERANCES

FRACTIONS
± 1/64
ANGLES
± 0° 30'

CODE
A