

REVISIONS						
ZONE	LTR	DESCRIPTION	DATE	E.M.N.NO	DRAFT	CHKD APPD
	X	EXP. RELEASE	8.21.68		H.S.	JAD
	Ø	ORIG. RELEASE FOR PROD	11/4/68	Ø	R.G.	
	A	ADD. A0128 ASSY NO.	7/16/69	-#	GE	WB

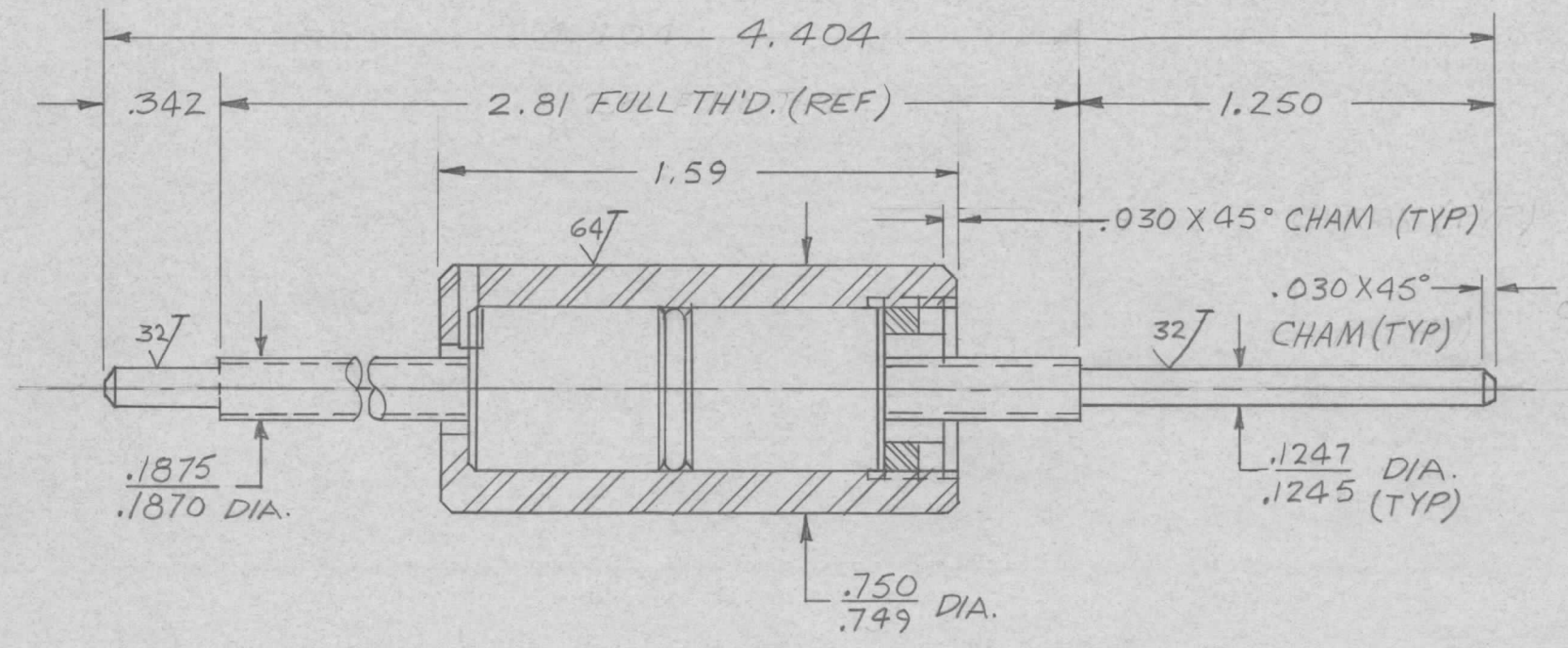

BALL TH'D DATA
.187 SCREW TH'D DIA.
20 TH'DS PER INCH~R.H.
.0005 MAX. LEAD ERROR
PER IN. OF BALL TH'D
CUMULATIVE
ADJUST BALL NUTS TO
WITHIN THE RANGE OF ZERO
BACKLASH TO 10 LBS PRELOAD

1	HFRR-4	A0128
QTY / UNIT	MODEL USED ON	ASS'Y NO.
APPLICATION		
	CODE	
NOTICE TO PERSONS RECEIVING THIS DRAWING THE TECHNICAL MATERIEL CORPORATION claims proprietary right in the material disclosed hereon. This drawing is issued in confidence for engineering information only and may not be reproduced or used to manufacture anything shown hereon without permission from THE TECHNICAL MATERIEL CORPORATION to the user. This drawing is loaned for mutual assistance and is subject to recall at any time.		

UNLESS OTHERWISE SPECIFIED DIMENSIONS ARE IN INCHES AND INCLUDE CHEMICALLY APPLIED OR PLATED FINISHES	
DECIMALS	FRACTIONS
.X ± .05	1/64
.XX ± .01	ANGLES
.XXX ± .005	0° -30'
TOLS.	
MATERIAL	
FINISH	

REQ'D	ITEM	PART NUMBER	DESCRIPTION	SYM.
LIST OF MATERIAL				
FINAL APPROVAL <i>[Signature]</i> DATE 11-1-68 MECH. DES. <i>[Signature]</i> DATE 10/30/68 ELECT. DES. <i>[Signature]</i> DATE 8.21.68 CHECKED <i>[Signature]</i> DATE 8.21.68 DRAWN <i>[Signature]</i> DATE 8.21.68				
THE TECHNICAL MATERIEL CORP. MAMARONECK, NEW YORK BALL SCREW, ASS'Y				
S401-473 (M 305-11777)		SIZE B	CODE IDENT. NO. 82679	DWG NO. PO 320
SCALE ++		SHEET		OF A