

REQ. PER UNIT	USED ON		
	MODEL	ASS'Y. NO.	DATE
1	GPT-200K	AX-397	10-14-63

PO-293 0

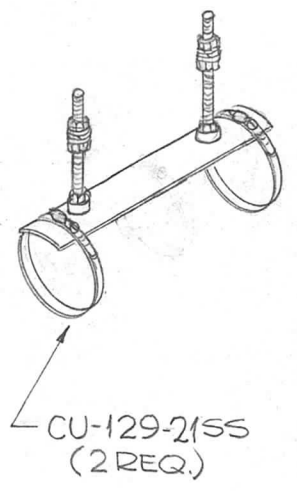
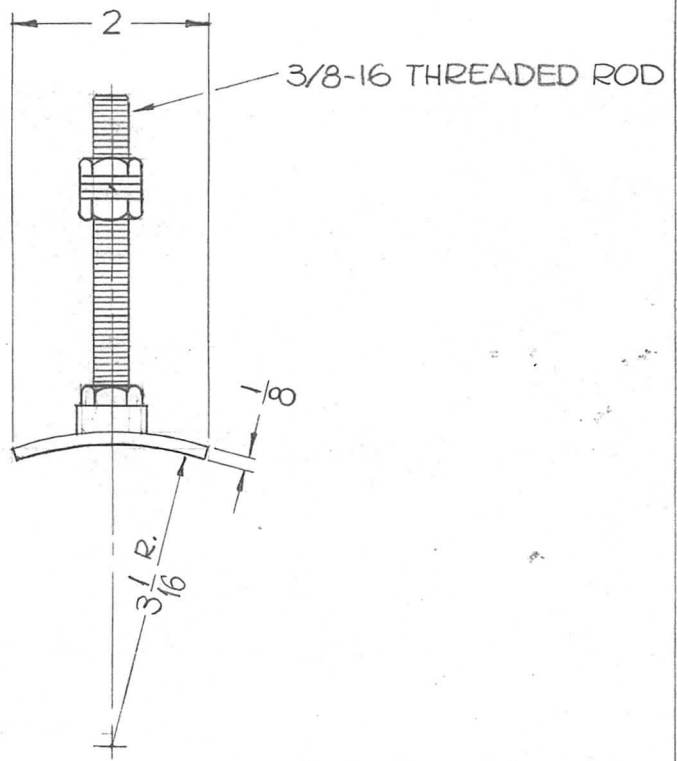
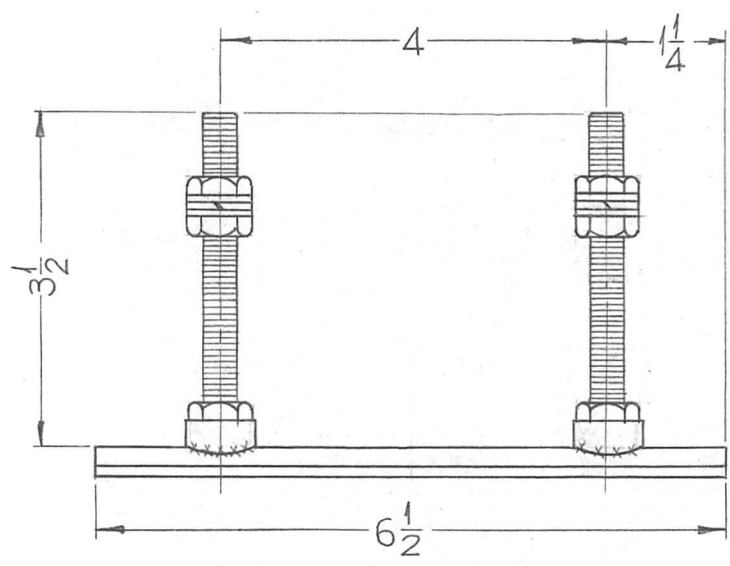

REF. ID-292

REQ.	ITEM	PART NO.	F. BUDETTI	DESCRIPTION	SYMBOL								
0				THE TECHNICAL MATERIEL CORP. MAMARONECK, NEW YORK									
				HANGER, 6-1/8 LINE									
0				ORIGINAL RELEASE FOR PRODUCTION									
			5-27-64	O A.M.									
X1			1-9-64	3-1/16 R WAS 3-1/8 R CU-129-2155 WAS CU-129-7-55									
SYM	DESCRIPTION	DATE	CH. NO.	DRAFTS	CHECKER	ENG. APP.	MATERIAL	TYPE & TEMPER	HEAT TREAT. SPEC.	DRAWN	CHECKED	FINAL APPROVAL	
	UNLESS OTHERWISE SPECIFIED DIMENSIONS ARE IN INCHES AND INCLUDE CHEMICALLY APPLIED OR PLATED FINISHES	SCALE	1/2" = 1"								SRG	qa	Roc
	DECIMALS .X ± .05 .XX ± .01 .XXX ± .005	TOLERANCES	FRACTIONS ± 1/64 ANGLES ± 0° 30'	CODE	S401-276 (P/O 601-083)					DOB	12/17/63	PO-293 0	
							FINISH & SPEC. NO.			ELEC. DES. APP.	MECH. DES. APP.		