

APPLICATION			REVISIONS						
QTY	MODEL USED ON	ASS'Y NO.	LTR	DESCRIPTION	DATE	E.M.N.NO	DRAFT	CHKD	APPD
	SEE CHART		X	EXP. RELEASE	11/27/68		KH		
			Ø	ORIG. RELEASE FOR PROD	12-6-68	Ø	R.G.		

TMC PART NO.	LENGTH	MODEL USED ON	QTY
PM 8003 - 1	2 1/2	SPT 3 KVHF AX 8080	1
PM 8003 - 2	5 3/4	SPT 3 KVHF AX 8080	1

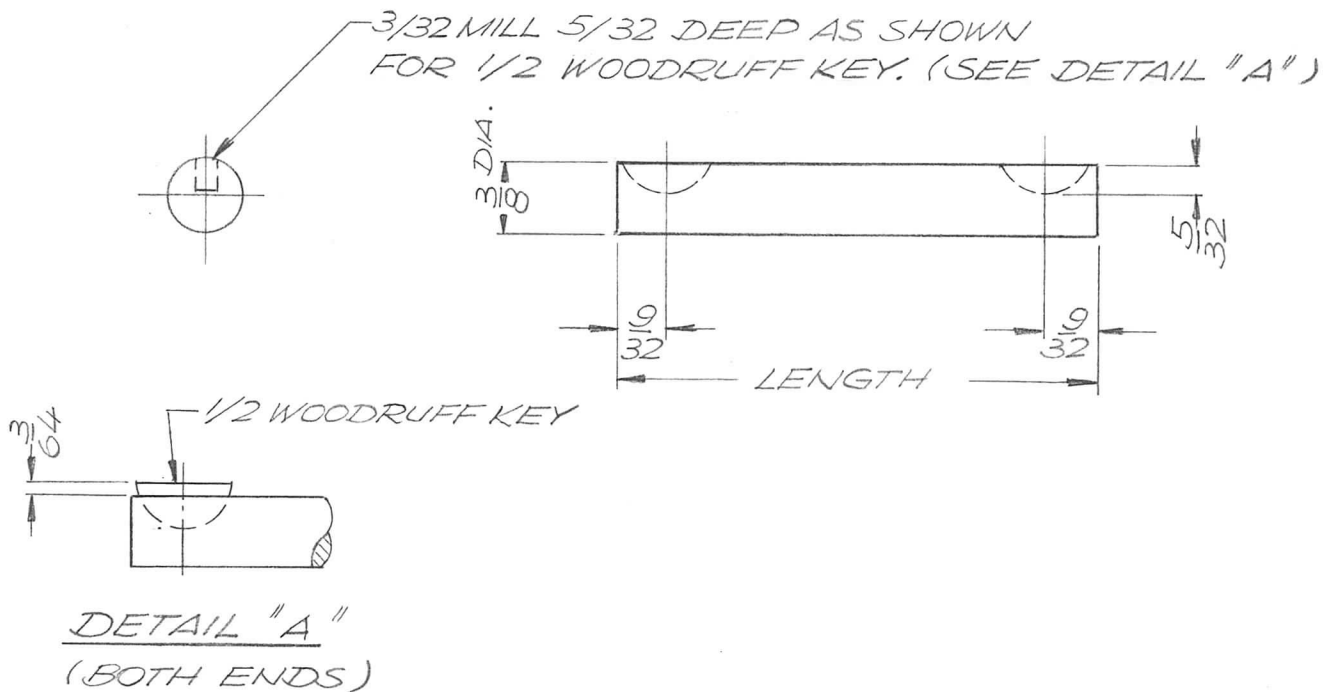

NOTE: 1/2 WOODRUFF KEY IS SUPPLIED

UNLESS OTHERWISE SPECIFIED DIMENSIONS ARE IN INCHES AND INCLUDE CHEMICALLY APPLIED OR PLATED FINISHES		REQ'D	ITEM	PART NUMBER	DESCRIPTION	SYM.
LIST OF MATERIAL						
DECIMALS FRACTIONS .X ± .05 1/64 .XX ± .01 TOLS. ANGLES .XXX ± .005 0° - 30°		FINAL APPROVAL		DATE	THE TECHNICAL MATERIEL CORP. MAMARONECK, NEW YORK SHAFT, COUPLING	
MATERIAL 303 STAINLESS STEEL		MECH. DES.		DATE		
FINISH		ELECT. DES.		DATE		
		CHECKED		DATE		
		DRAWN		DATE		
NOTICE TO PERSONS RECEIVING THIS DRAWING THE TECHNICAL MATERIEL CORPORATION claims proprietary right in the material disclosed hereon. This drawing is issued in confidence for engineering information only and may not be reproduced or used to manufacture anything shown hereon without permission from THE TECHNICAL MATERIEL CORPORATION to the user. This drawing is loaned for mutual assistance and is subject to recall at any time.					SIZE	ISSUE
					A	Ø
					CODE IDENT. NO.	
					82679	
					DWG NO.	
					PM 8003	
					SCALE	
					1 : 1	
					SHEET	
					OF	