

REQ. PER UNIT	USED ON			PM-626	D
	MODEL	ASS'Y. NO.	DATE		
1	AT-106	GPT-40K	3-16-60		

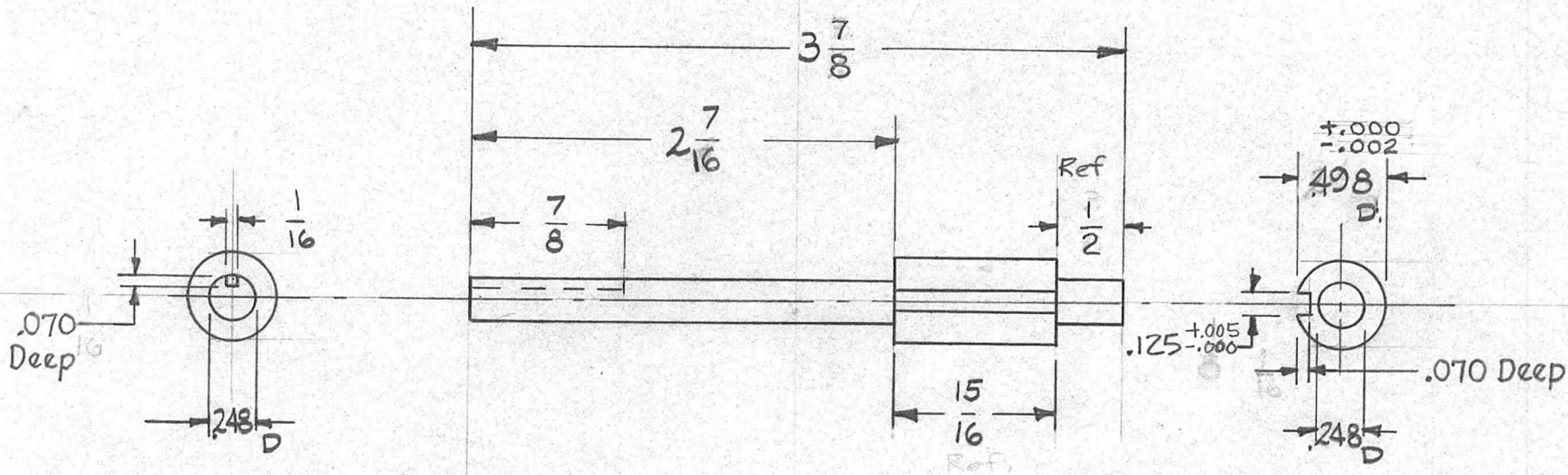

D	2	±TOL. ADD TO .498 D. DIM. U/O: MODEL WAS AT-101	1-8-65	13260	JL	JL	OB	REQ. ITEM	PART NO.	DESCRIPTION	SYMBOL								
C	1	3 7/8 WAS 3 3/4, 1/2 WAS 3/8	5.25.64	11449	WB	WB	OB	THE TECHNICAL MATERIEL CORP. MAMARONECK, NEW YORK											
B	1	.125 ^{+.005} / _{-.000} WAS 1/8	1/30/64	10807	FW	T.R.	WB	STAINLESS STEEL											
A	1	on slots .070 deep was 1/16	4/26/61	4769	JM	JCS	OB	SHAFT, SWITCH											
ISSUE	ITEM	CHANGED FROM	DATE	CH. NO.	DRAFTS	CHECKER	ENG. APP.	MATERIAL											
TOLERANCES			SCALE: FULL					DRAWN: JORILLO											
DEC. DIM. ±			MAXIMUM ALLOWABLE TOLERANCES HAVE BEEN DETERMINED AND ANY DEVIATIONS WILL BE CAUSE FOR REJECTION. REMOVE ALL BURRS AND SHARP EDGES					TYPE & TEMPER		HEAT TREAT. SPEC.		DRAWN		CHECKED		FINAL APPROVAL			
FRAC. DIM. ±								PASSIVATE						L6		OB			
ANGULAR DIM. ± 1/64								FINISH & SPEC. NO.								PM-626		D	
								ELEC. DES. APP.		MECH. DES. APP.									