

REQ. PER. UNIT	USED ON			PM-587	E
	MODEL	ASS'Y. NO.	DATE		
1	GPT-40K	AX-209	3/3/60		
1	GPT-40K()3 AS-120	AX-353	12-23-63		
1	GPT-40K()4 AS-125	AX-458	12-23-63		

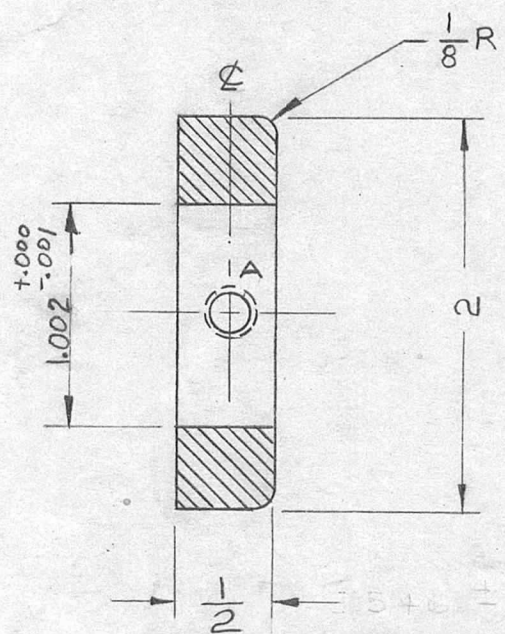

SECTION "A"

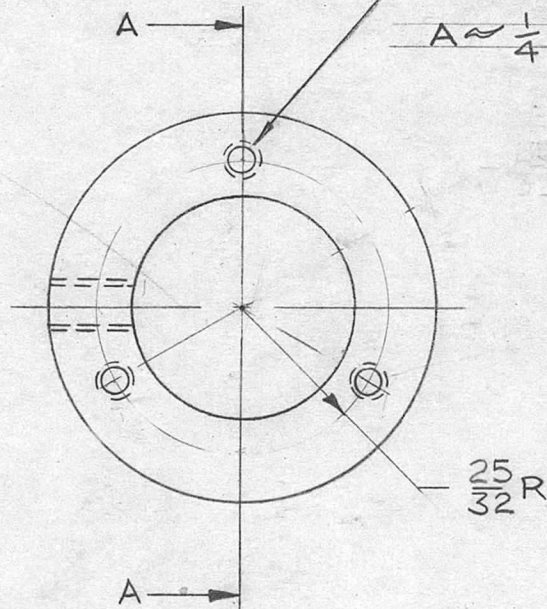

8-32 DRILL & TAP  
120° APART 3 REQ'D  
A ~ 1/4 -20 TAP 1 REQ'D

F	1	DWG UPDATED	1/23/63	10692	<del>SA</del>	Jide	DB
E	1	ADD 1/4-20 TAP	4-19-60	2146	CY	Jide	
D	2	IN SEC. A TOLERANCE ADDED	3-21-60	~	NA	Jide	16
	1	DELETED NOTE (SNUG FIT)					
C		ADDED NOTE	3/17/60	+	ALL	Jide	16
B	1	1/2 WAS .546	3/3/6	+	CY	Jide	DB
A	1	.546 WAS 1/2	3/3/6	+	CY	Jide	DB
ISSUE	ITEM	CHANGED FROM	DATE	CH. NO.	DRAFTS	CHECKER	ENG. APP.
TOLERANCES			SCALE: FULL				
DEC. DIM. ±			MAXIMUM ALLOWABLE TOLERANCES HAVE BEEN DETERMINED AND ANY DEVIATIONS WILL BE CAUSE FOR REJECTION. REMOVE ALL BURRS AND SHARP EDGES				
FRAC. DIM. ± 1/64							
ANGULAR DIM. ±							

REQ.	ITEM	PART NO.	DESCRIPTION		SYMBOL
			THE TECHNICAL MATERIEL CORP.		
			MAMARONECK, NEW YORK		
			HOLDER, BEARING		
			MATERIAL		
			1/2 H	CY	Jide
			TYPE & TEMPER	HEATTREAT. SPEC.	DRAWN
			NICKEL PLATED	.0005	CHECKED
			FINISH & SPEC. NO.	ELEC. DES. APP	MECH. DES. APP
					FINAL APPROVAL
					PM-587
					E