

REQ. PER. UNIT	USED ON			PM-585
	MODEL	ASS'Y. NO.	DATE	
1	SBE-2 A-1516	A-1517	11-25-59	
1	SBE-3 AB-100	A-1517	12-3-59	

DRILL & C'SINK FOR 6-32 F.H.S.

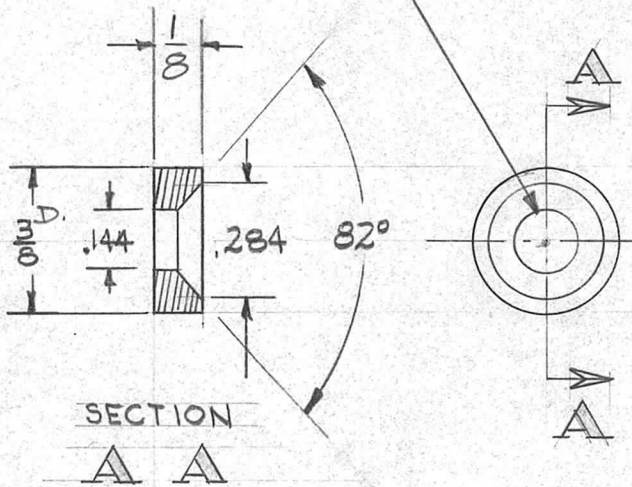

ALTERNATE MFG. METHOD
TMC PART # TE-117-26 MAY
BE MODIFIED AS SHOWN.

REQ.	ITEM	PART NO.	DESCRIPTION			SYMBOL	
		3/8 O.D.	THE TECHNICAL MATERIEL CORP.				
		STOCK SIZE	MAMARONECK, NEW YORK				
		BRASS	STOP SPACER, GEAR				
		MATERIAL					
ISSUE	ITEM	CHANGED FROM	DATE	CH. NO.	DRAFTS	CHECKER	ENG. APP.
TOLERANCES			SCALE: DOUBLE				
DEC. DIM. ±			MAXIMUM ALLOWABLE TOLERANCES HAVE BEEN DETERMINED AND ANY DEVIATIONS WILL BE CAUSE FOR REJECTION. REMOVE ALL BURRS AND SHARP EDGES				
FRAC. DIM. ±							
ANGULAR DIM. ±							
TYPE & TEMPER		HEATTREAT. SPEC.	DRAWN	CHECKED	FINAL APPROVAL		
NICKEL PLATE					PM-585		
FINISH & SPEC. NO.			ELEC. DES. APP	MECH. DES. APP			