

REQ. PER. UNIT	USED ON			PM-550	A
	MODEL	ASS'Y. NO.	DATE		
1	AX-123. (10K)	A-1689	2-13-59		

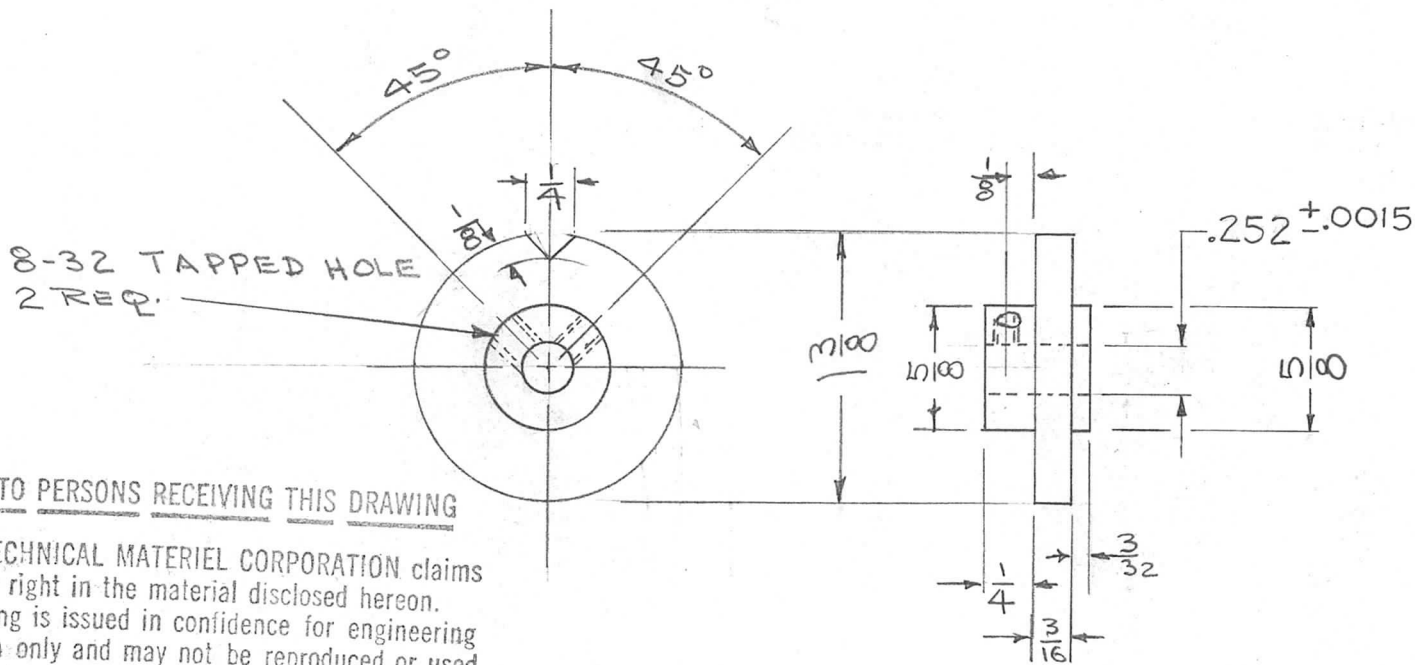

NOTICE TO PERSONS RECEIVING THIS DRAWING

THE TECHNICAL MATERIEL CORPORATION claims proprietary right in the material disclosed hereon. This drawing is issued in confidence for engineering information only and may not be reproduced or used to manufacture anything shown hereon without permission from THE TECHNICAL MATERIEL CORPORATION to the user. This drawing is loaned for mutual assistance and is subject to recall at any time.

Property of:

THE TECHNICAL MATERIEL CORPORATION  
MAMARONECK, NEW YORK

REQ.	ITEM	PART NO.	DESCRIPTION			SYMBOL
			THE TECHNICAL MATERIEL CORP. MAMARONECK, NEW YORK			
			STOCK SIZE			
			BRASS			
			MATERIAL			
			1/2 HARD			
			TYPE & TEMPER HEATTREAT. SPEC.			
			NICKEL PLATE			
			FINISH & SPEC. NO.			
A	1	.252 ± .0015 was 1/4"	3/24/59	J.C.B.	<i>[Signature]</i>	<i>[Signature]</i>
ISSUE	ITEM	CHANGED FROM	DATE	CH. NO.	DRAFTS	CHECKER
TOLERANCES			SCALE:			
DEC. DIM. ±			MAXIMUM ALLOWABLE TOLERANCES HAVE BEEN DETERMINED AND ANY DEVIATIONS WILL BE CAUSE FOR REJECTION.			
FRAC. DIM. ±			REMOVE ALL BURRS AND SHARP EDGES			
ANGULAR DIM. ±						
			DRAWN			CHECKED
			<i>[Signature]</i>			<i>[Signature]</i>
			ELEC. DES. APP			MECH. DES. APP
			PM-550			A