

SYMBOL		DESCRIPTION	PART NO.	REQ. ITEM	STOCK SIZE	THE TECHNICAL MATERIEL CORP. MAMARONECK, NEW YORK		CONTACT	
D					3/4-DIA				
C					4				
C									
B									
A									
ISSUE ITEM		CHANGED FROM	DATE	CH. NO.	DRAFTS	CHECKER	ENG. APP.	TOLERANCES	
D		REMOVED COUNT SINK	3/24/87					SCALE:	
C		ADD 4-40 TAP HOLE						MAXIMUM ALLOWABLE TOLERANCES HAVE BEEN DETERMINED AND ANY DEVIATIONS WILL BE CAUSE FOR REJECTION.	
C		HOLE FROM 48 TO 56 DIA						REMOVE ALL BURRS AND SHARP EDGES	
C		DIM 5/32 TO 1/8 DIA TO .750						DEC. DIM. $\pm$	
B		ADD DIM. 71.5 $\pm$ .003	7.13.72	20785	GE	Q.		FRAG. DIM. $\pm$ $\sqrt{64}$	
A		1/8 WAS 1"	6-11-52	1	CSB	AMC		ANGULAR DIM. $\pm$	
TOLERANCES		SCALE:		FINISH & SPEC. NO.		ELEC. DES. APP.		MECH. DES. APP.	
				NICKEL PLATE				PM-371 D	
				TYPE & TEMPER		DRAWN		CHECKED	
				FREE TURNING		P3 16-20-55		PAW	
				HEAT TREAT. SPEC.				FINAL APPROVAL	

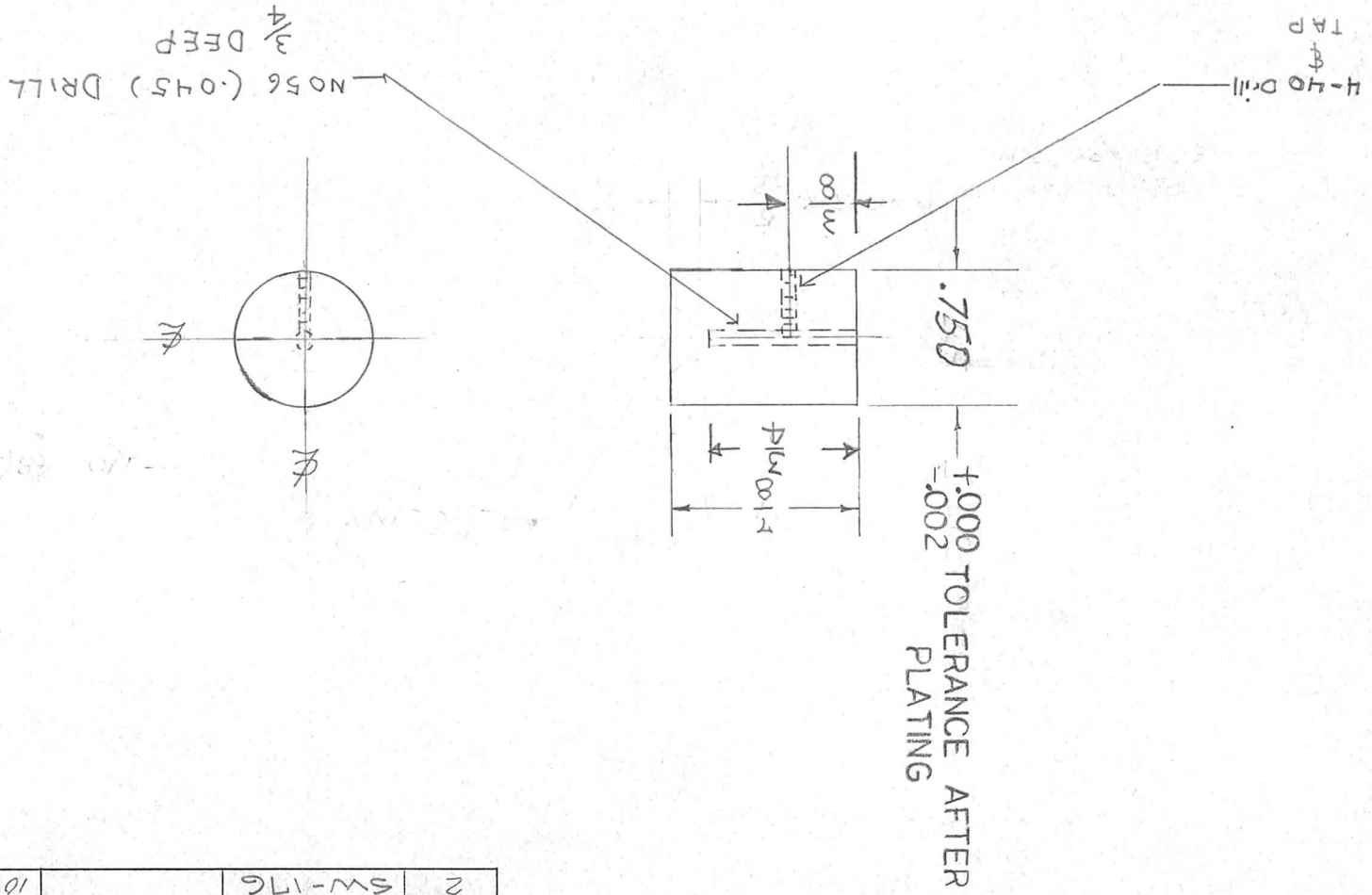

REQ. PER UNIT	MODEL	ASS'Y. NO.	DATE
2	5W-17G		10-20-55
USED ON			
PM-371 D			