

IF IT IS FOUND DESIRABLE TO CHANGE ANY TOLERANCE OR OTHER DETAIL SPECIFIED ON THIS DRAWING NOTIFY THE PURCHASER PROMPTLY.

PM-225 B

MAXIMUM ALLOWABLE TOLERANCES HAVE BEEN DETERMINED AND DEVIATIONS WILL BE CAUSE FOR REJECTION. REMOVE ALL BURRS AND SHARP EDGES

REQ PER UNIT	USED ON			
	MODEL	PROJECT NO.	ASS'Y. NO.	DATE
1	VOX	101	A-415	3-4-53
1	PMO-2	285		8-16-54
1	VOX-1	291		1/17/55
1	VOX-2	291		1/17/55
2	GPR	297		4-4-55
1	RTF			2-1-56
1	RTF-2	F/P		11-20-58

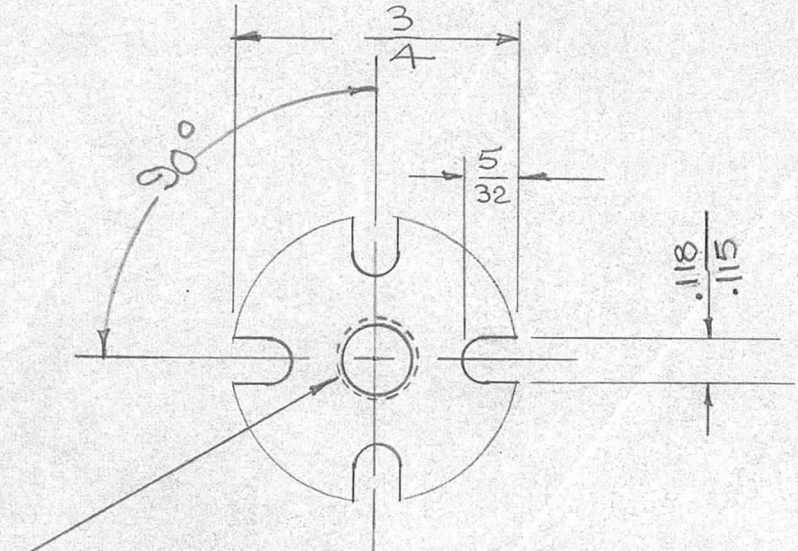

10-32 RIGHT HAND THREAD - CLASS 2

REQ.	ITEM	PART NO.	DESCRIPTION	SYMBOL
		1/16 THICK	THE TECHNICAL MATERIEL CORP. MAMARONECK, NEW YORK	
		STOCK SIZE		
		STEEL	PLATE, DIAL LOCKING	
		MATERIAL		
		WEIGHT PER PC.	R. H.	
		COLD ROLLED		
		TYPE & TEMPER	C.D.D. 3-4-53	
			DRAWN	ELEC. DES. APP.
			CHECKED	FINAL APPROVAL
		HEAT TREAT. SPEC.		
		S-105 CAD. PLATE		
		.0003		
		FINISH & SPEC. NO.		

ISSUE	ITEM	CHANGED FROM	DATE	CN. NO.	DRAFTS	CHECKER	ENG. APP.
B	1	.118 DIM. WAS .117	12-3-58	2	J.C.B.		
A	1	DIM. ADDED	8/27/56	1			

TOLERANCES		SCALE
ALL OTHERS	DEC. DIM. ± FRAC. DIM. ± 1/64 ANGULAR DIM. ± 10'	DRILL, PUNCH, COMMERCIAL STOCK SIZES AND MANUFACTURERS TOLERANCES ARE NOT INCLUDED.

SUPERCEDES BMS079
 (C)
 PM-225 B