

APPLICATION			REVISIONS							
QTY	MODEL USED ON	ASS'Y NO.	LTR	DESCRIPTION	DATE	E.M.N.NO	DRAFT	CHKD	APPD	
1	HFTA-10K		Ø	ORIGINAL RELEASE FOR PRODUCTION	9-26-58		dw			

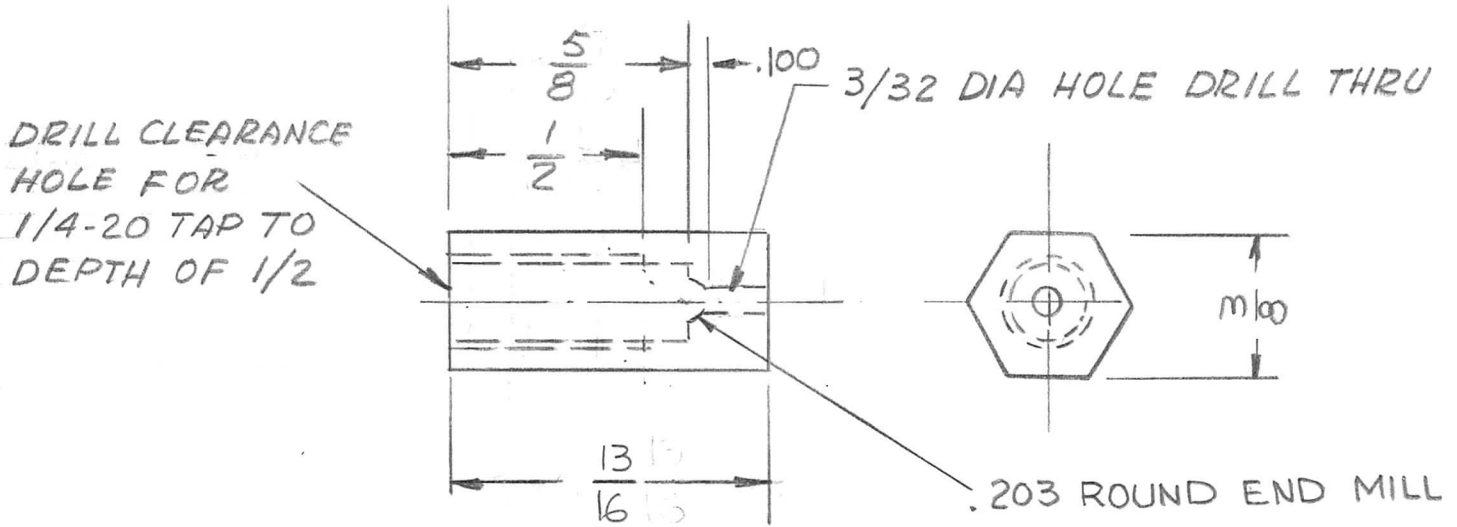

UNLESS OTHERWISE SPECIFIED DIMENSIONS ARE IN INCHES AND INCLUDE CHEMICALLY APPLIED OR PLATED FINISHES

REQ'D	ITEM	PART NUMBER	DESCRIPTION	SYM.
LIST OF MATERIAL				
FINAL APPROVAL <i>OTB</i>			DATE 10-26-60	THE TECHNICAL MATERIEL CORP. MAMARONECK, NEW YORK WIRE HOLDER
MECH. DES.		DATE		
ELECT. DES.		DATE		
CHECKED		DATE		
DRAWN <i>GDL</i>		DATE 1-24-77		

DECIMALS .X ± .05 .XX ± .01 .XXX ± .005	FRACTIONS 1/64 ANGLES 0° - 30'
MATERIAL BRASS	
FINISH NATURAL	

NOTICE TO PERSONS RECEIVING THIS DRAWING
THE TECHNICAL MATERIEL CORPORATION claims proprietary right in the material disclosed hereon. This drawing is issued in confidence for engineering information only and may not be reproduced or used to manufacture anything shown hereon without permission from **THE TECHNICAL MATERIEL CORPORATION** to the user. This drawing is loaned for mutual assistance and is subject to recall at any time.

SIZE A	CODE IDENT. NO. 82679	DWG NO. PM 1593	ISSUE Ø
SCALE 2:1		SHEET	OF