

REVISIONS							
E.M.N. NO.	DRAFT	CHKD	ZONE	LTR	DESCRIPTION	DATE	APPROVED
	DV			Ø	ORIGINAL RELEASE FOR PRODUCTION	11/30/73	

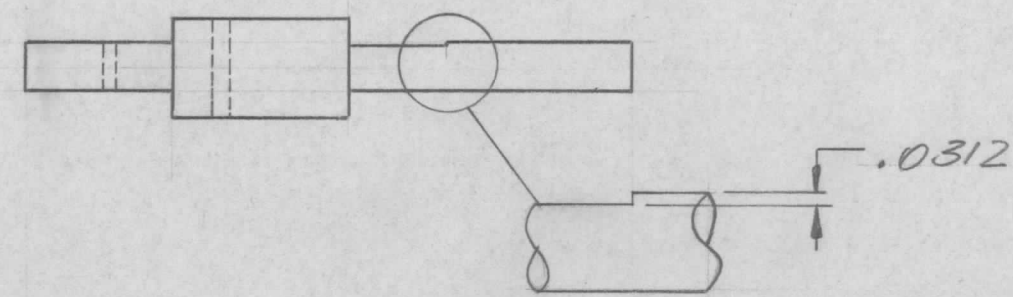
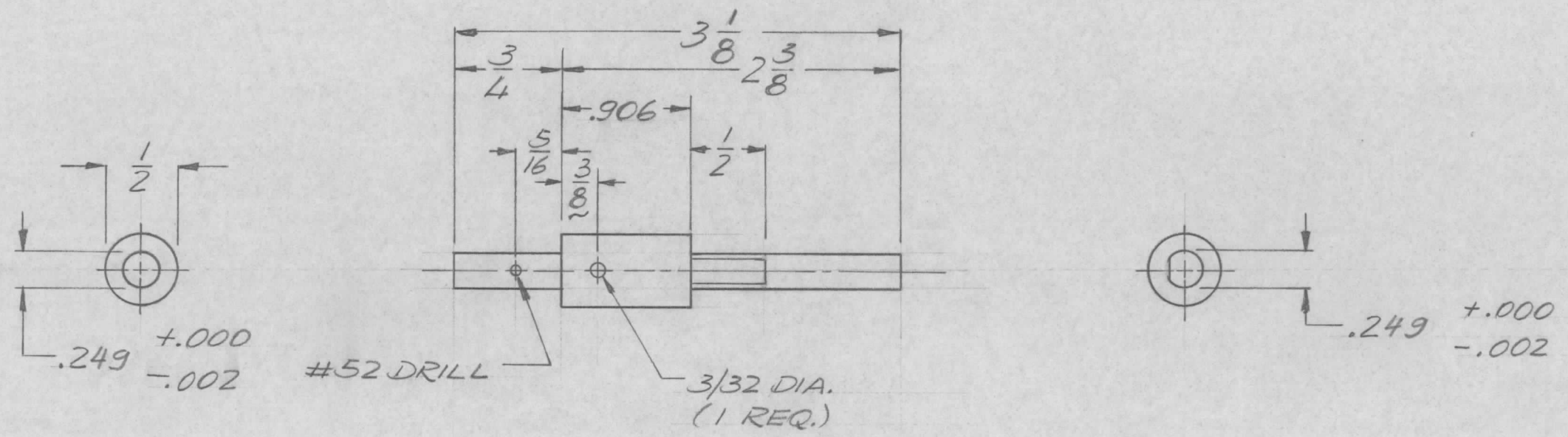

FLAT DETAIL

REQ'D	ITEM	PART NUMBER	DESCRIPTION	SYM.
			F.B. LIST OF MATERIAL	
UNLESS OTHERWISE SPECIFIED DIMENSIONS ARE IN INCHES AND INCLUDE CHEMICALLY APPLIED OR PLATED FINISHES		FINAL APPROVAL	DATE	
DECIMALS .X ± .05 FRACTIONS 1/64		MECH. DES.	DATE	
.XX ± .01 TOLS. ANGLES		ELECT. DES.	DATE	
.XXX ± .005 0° .30'		CHECKED	DATE	
MATERIAL		DRAWN	DATE	
S. STEEL		GE	3/9/73	
FINISH		SIZE	CODE IDENT. NO.	DWG NO.
		B	82679	PM1555
NOTICE TO PERSONS RECEIVING THIS DRAWING THE TECHNICAL MATERIEL CORPORATION claims proprietary right in the material disclosed hereon. This drawing is issued in confidence for engineering information only and may not be reproduced or used to manufacture anything shown hereon without permission from THE TECHNICAL MATERIEL CORPORATION to the user. This drawing is loaned for mutual assistance and is subject to recall at any time.		SCALE	SHEET	OF

QTY / UNIT	MODEL USED ON	ASS'Y NO.
1	AX5176	AX5179
APPLICATION		
	CODE	

THE TECHNICAL MATERIEL CORP.
MAMARONECK, NEW YORK

SHAFT, CAP PULLEY