

APPLICATION			REVISIONS						
QTY	MODEL USED ON	ASS'Y NO.	LTR	DESCRIPTION	DATE	E.M.N.NO	DRAFT	CHKD	APPD
1	TLAA-1K	AX5132	0	ORIGINAL RELEASE	4/4/73		8		

DRILL CLEARANCE HOLE FOR  
 1/4-20 TAP TO DEPTH OF 5/8.  
 TAP 1/4-20 THD TO DEPTH OF 1/2

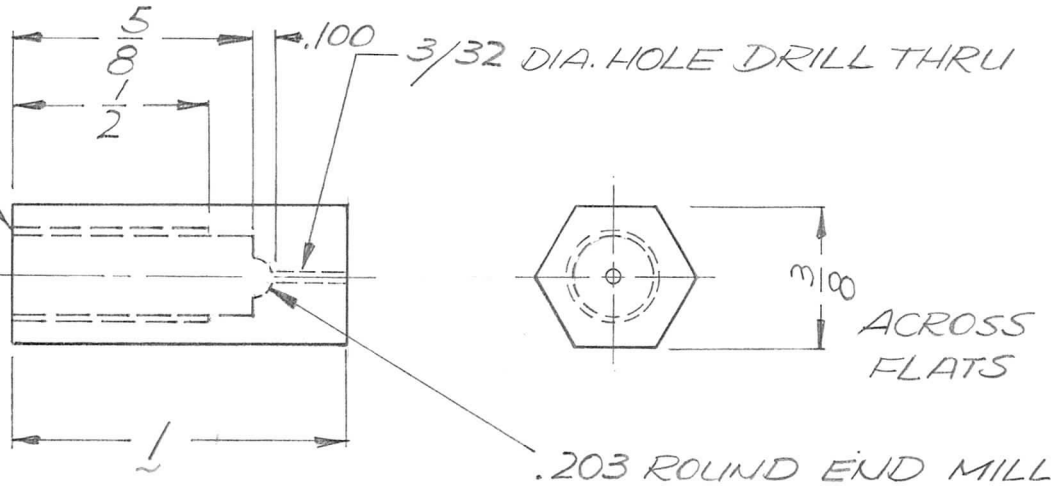

UNLESS OTHERWISE SPECIFIED DIMENSIONS ARE IN INCHES AND INCLUDE CHEMICALLY APPLIED OR PLATED FINISHES		REQ'D	ITEM	PART NUMBER	DESCRIPTION	SYM.
DECIMALS: .X ± .05, .XX ± .01, .XXX ± .005 FRACTIONS: 1/64, ANGLES: 0° - 30'		<b>F.B.</b> LIST OF MATERIAL				
<b>MATERIAL</b> BRASS		FINAL APPROVAL <i>JMM</i> MECH. DES. <i>JMM</i> ELECT. DES. CHECKED DRAWN <i>GE</i>	DATE 29 MAR 73 DATE 29 MAR 73 DATE DATE DATE 3/24/72	<b>THE TECHNICAL MATERIEL CORP.</b> MAMARONECK, NEW YORK  WIRE HOLDER		

<b>NOTICE TO PERSONS RECEIVING THIS DRAWING</b> THE TECHNICAL MATERIEL CORPORATION claims proprietary right in the material disclosed hereon. This drawing is issued in confidence for engineering information only and may not be reproduced or used to manufacture anything shown hereon without permission from THE TECHNICAL MATERIEL CORPORATION to the user. This drawing is loaned for mutual assistance and is subject to recall at any time.				SIZE <b>A</b>	CODE IDENT. NO. <b>82679</b>	DWG NO. <b>PM1520</b>	ISSUE <b>0</b>
SCALE <b>2:1</b>			SHEET OF				