

| | | | | | |
|---------------|---------|------------|---------|--------|---|
| REQ. PER UNIT | USED ON | | | PM1268 | Ø |
| | MODEL | ASS'Y. NO. | DATE | | |
| 5 | TST-10K | | 6-10-65 | | |

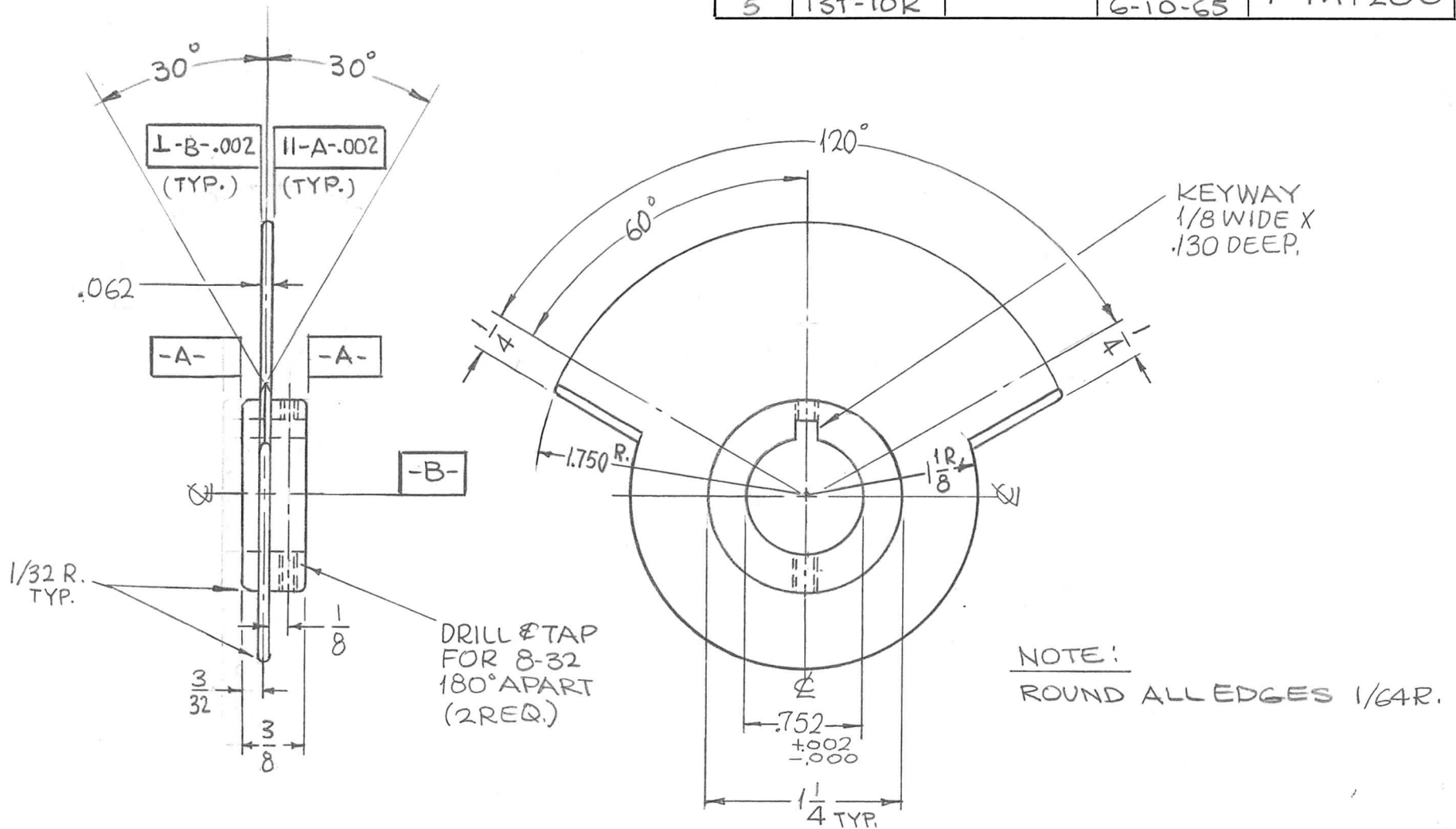

| SYM | DESCRIPTION | DATE | CH. NO. | DRAFTS | CHECKER | ENG. APP. | REQ. ITEM | PART NO. | F. BUDETTI DESCRIPTION | SYMBOL | | |
|---|---------------------------------|---------|---------|--------|---------|-----------|---|----------|--|-------------------|-----------------|--|
| Ø | ORIGINAL RELEASE FOR PRODUCTION | 3-3-66 | -A- | JC | JCB | arc | AS NOTED | | THE TECHNICAL MATERIEL CORP. MAMARONECK, NEW YORK | | | |
| X2 | 3/32 WAS 9/32, 3/8 WAS 9/16 | 8-11-65 | X2 | | | | STOCK SIZE | | | | | |
| X1 | SYMBLS I & II ADDED | 6-22-65 | X1 | G.D.L. | RA | | BRASS | | | ROTOR, BANDSWITCH | | |
| UNLESS OTHERWISE SPECIFIED DIMENSIONS ARE IN INCHES AND INCLUDE CHEMICALLY APPLIED OR PLATED FINISHES | | | | | | | SCALE | | | | | |
| | | | | | | | 1:1 | | | | | |
| DECIMALS .X ± .05 .XX ± .01 .XXX ± .005 | | | | | | | FRACTIONS ± 1/64 ANGLES ± 0° 30' | | CODE | A | | |
| TOLERANCES | | | | | | | MATERIAL | | HALF HARD | | | |
| | | | | | | | TYPE & TEMPER | | HEAT TREAT. SPEC. | | | |
| | | | | | | | S245 SILVER PLATE | | S423 SILVER KOTE | | | |
| | | | | | | | FINISH & SPEC. NO. | | ELEC. DES. APP. | | MECH. DES. APP. | |
| | | | | | | | | | DRAWN | | CHECKED | |
| | | | | | | | | | FINAL APPROVAL | | PM1268 Ø | |