

REQ. PER UNIT	USED ON			PM1212	Ø
	MODEL	ASS'Y. NO.	DATE		
1	RFTA-1		2-16-65		

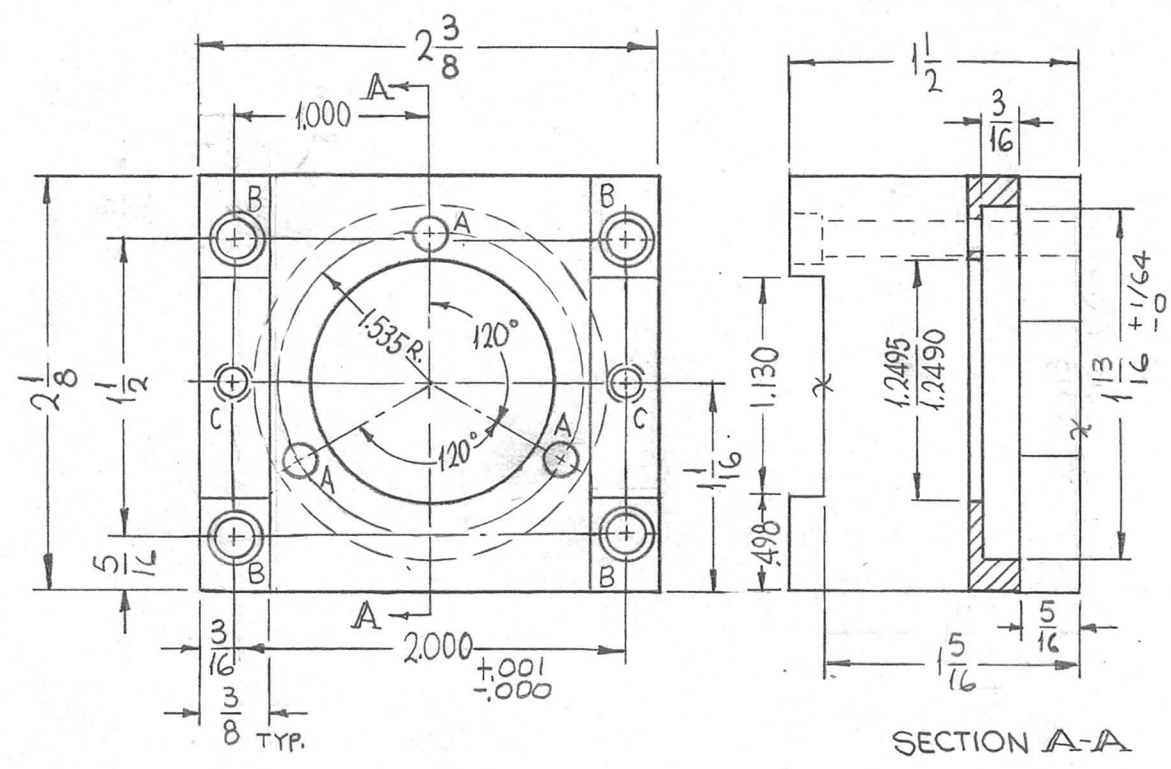

HOLES	DESCRIPTION	REQ
A	5/32 DIA.	3
B	DR. 13/64 D. C BORE 9/32 D. X 3/16 DP.	4
C	DR. & TAP 10-32 X 1/2 DP.	2

REF: CS 133
REF: MS 4776

Ø	ORIGINAL RELEASE FOR PRODUCTION	3-3-66	AA	Jc	JCB	orc	REQ. ITEM	PART NO.	F. BUDETTI	DESCRIPTION	SYMBOL	
X ₁	COMPLETELY REVISED	9-28-65	X ₁				STOCK SIZE		THE TECHNICAL MATERIEL CORP. MAMARONECK, NEW YORK			
X	EXP. RELEASE	2-16-65	X	SRG			SEE CASTING		MACHINING, MOTOR MOUNT			
SYM	DESCRIPTION	DATE	CH. NO.	DRAFTS	CHECKER	ENG. APP.	MATERIAL					
UNLESS OTHERWISE SPECIFIED DIMENSIONS ARE IN INCHES AND INCLUDE CHEMICALLY APPLIED OR PLATED FINISHES		SCALE	1:1						SRG	JCB		
DECIMALS .X ± .05 .XX ± .01 .XXX ± .005		TOLERANCES		FRACTIONS ± 1/64 ANGLES ± 0° 30'		CODE A	S404 YEL. IRIDITE	HEAT TREAT. SPEC.	DRAWN	CHECKED	FINAL APPROVAL	
							FINISH & SPEC. NO.	ELEC. DES. APP.	MECH. DES. APP.	PM1212	Ø	