

REQ. PER UNIT	USED ON			PM1187 $\emptyset$
	MODEL	ASS'Y. NO.	DATE	
1	TST-10K		6-24-65	

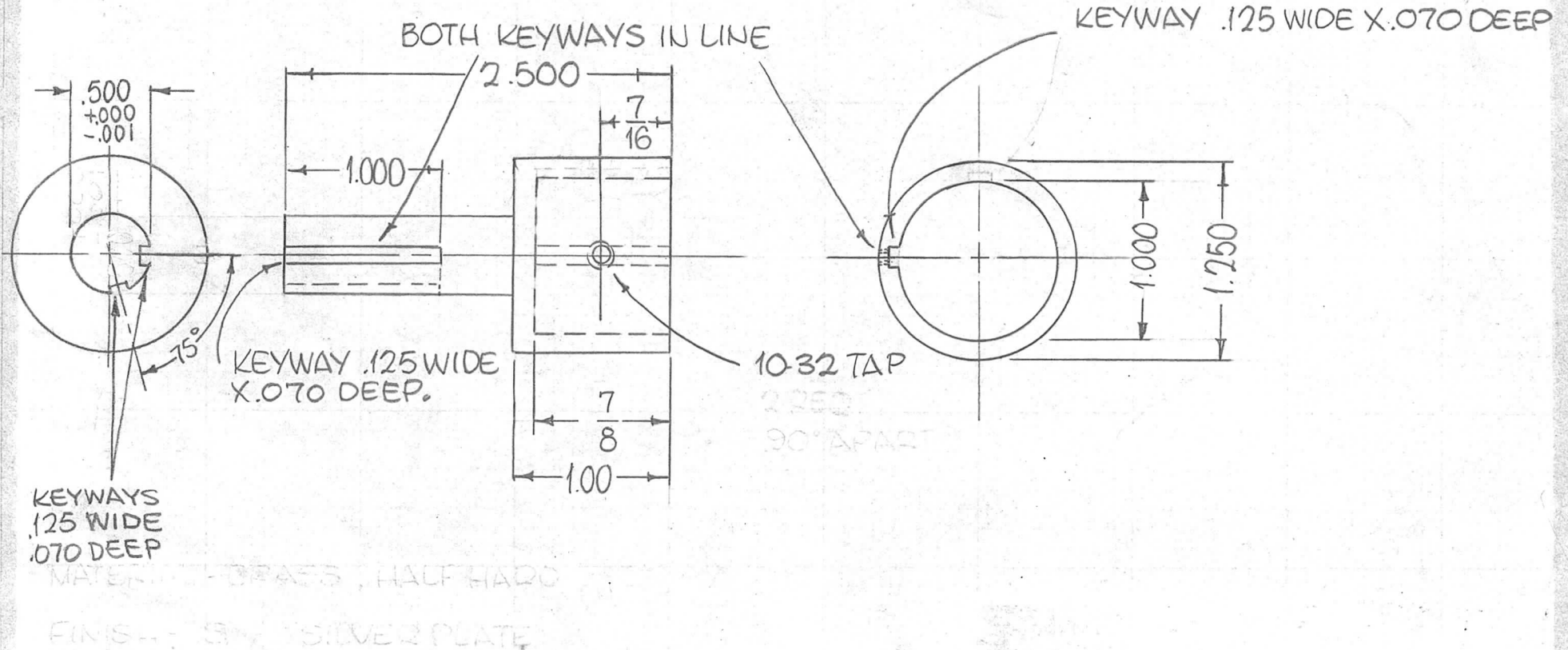

SYM	DESCRIPTION	DATE	CH. NO.	DRAFTS	CHECKER	ENG. APP.	REQ. ITEM	PART NO.	F. BUDETTI	DESCRIPTION	SYMBOL	
$\emptyset$	ORIGINAL RELEASE FOR PRODUCTION	4/20/66								THE TECHNICAL MATERIEL CORP. MAMARONECK, NEW YORK	$\emptyset$	
X2	1 KEYWAY ADDED	7-27-65	X2				SEE DWG					
X1	1 KEYWAY, 1 10-32 TAP, DELETED	6-24-65	X1				BRASS					
UNLESS OTHERWISE SPECIFIED DIMENSIONS ARE IN INCHES AND INCLUDE CHEMICALLY APPLIED OR PLATED FINISHES							SCALE					
DECIMALS .X $\pm$ .05 .XX $\pm$ .01 .XXX $\pm$ .005		FRACTIONS $\pm$ 1/64 ANGLES $\pm$ 0° 30'		CODE A			TYPE & TEMPER S245 SILVER PLATE S423 SILVER-KOTE		HEAT TREAT. SPEC.		FINISH & SPEC. NO.	
							DRAWN		CHECKED		FINAL APPROVAL	
							ELEC. DES. APP.		MECH. DES. APP.		PM1187 $\emptyset$	