

REQ. PER UNIT	USED ON		
	MODEL	ASS'Y. NO.	DATE
1	TST(1)10K	AM124	2-24-65
1	GPT10KLF		2-7-66

PM1170 | A

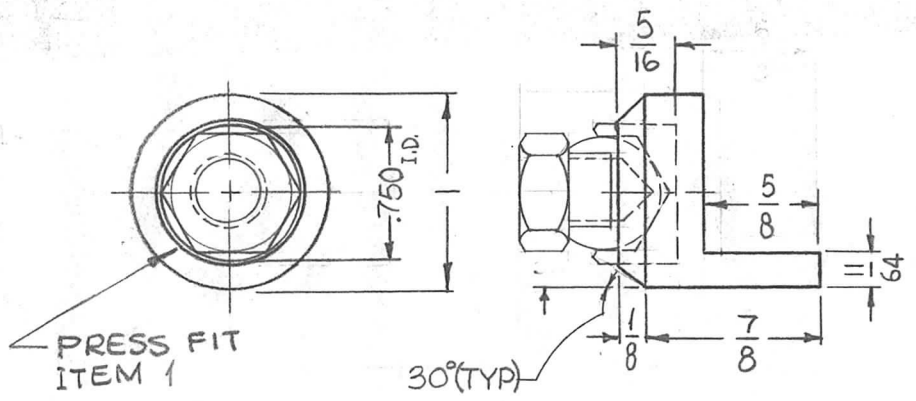

SYM	DESCRIPTION	DATE	CH. NO.	DRAFTS	CHECKER	ENG. APP.	REQ. ITEM	PART NO.	BUDETTI DESCRIPTION	SYMBOL		
A	ITEM 1 ADDED TO PICT	5-4-66	16202	440	QCB	QCB	1	NT150-2	NUT, PAD, TOGGLE			
Ø	ORIGINAL RELEASE	4/15/66	Ø			AB	1" DIA					
X2	ITEM NO 1 WAS NT150 (ERROR)	10/6/65	-M	JC		WRL	STOCK SIZE					
X1	P/N WAS PM1171 (ERROR), DWG WAS ALSO P/O A4113, LATCH ASS'Y	8/16/65	-M	JC		WRL	ALUMINUM					
UNLESS OTHERWISE SPECIFIED DIMENSIONS ARE IN INCHES AND INCLUDE CHEMICALLY APPLIED OR PLATED FINISHES							MATERIAL					
SCALE							2024-T4		SRG	QCB	FINAL APPROVAL	
DECIMALS .X ± .05 .XX ± .01 .XXX ± .005							TYPE & TEMPER		HEAT TREAT. SPEC.		DRAWN	
FRACTIONS ± 1/64 ANGLES ± 0° 30'							S404-IRIDIOTE, 14-2 AL-COAT				MECH. DES. APP.	
TOLERANCES							FINISH & SPEC. NO.		ELEC. DES. APP.		PM1170   A	
CODE A							A4113					