

REQ. PER UNIT	USED ON			PM1132	Ø
	MODEL	ASS'Y. NO.	DATE		
1	VLRB-1		8-28-64		

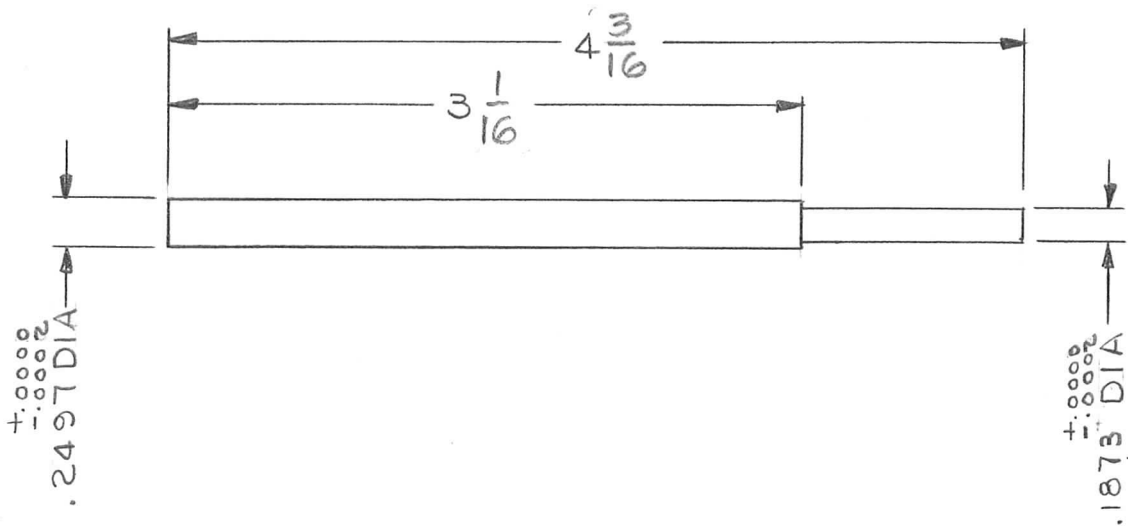

							REQ. ITEM	PART NO.	0. POSE	DESCRIPTION	SYMBOL
									THE TECHNICAL MATERIEL CORP. MAMARONECK, NEW YORK		
Ø	ORIGINAL RELEASE FOR PRODUCTION	4.9.65	Ø	JL				STOCK SIZE	SHAFT, STRAIGHT-TUNING		
X	EXPERIMENTAL REL.	8/28/64		JL				MATERIAL			
SYM	DESCRIPTION	DATE	CH. NO.	DRAFTS	CHECKER	ENG. APP.					
UNLESS OTHERWISE SPECIFIED DIMENSIONS ARE IN INCHES AND INCLUDE CHEMICALLY APPLIED OR PLATED FINISHES						SCALE	#303	J. LESHINSKI	@	Ø	
						1:1					
DECIMALS	TOLERANCES	FRACTIONS	CODE				TYPE & TEMPER	HEAT TREAT. SPEC.	DRAWN	CHECKED	FINAL APPROVAL
.X ± .05 .XX ± .01 .XXX ± .005		± 1/64 ANGLES ± 0° 30'	A				PASSIVATE				PM1132
							FINISH & SPEC. NO.	ELEC. DES. APP.	MECH. DES. APP.	Ø	