

REQ. PER UNIT	USED ON			PM1131	A
	MODEL	ASS'Y. NO.	DATE		
1	VLRB-1		10-20-64		

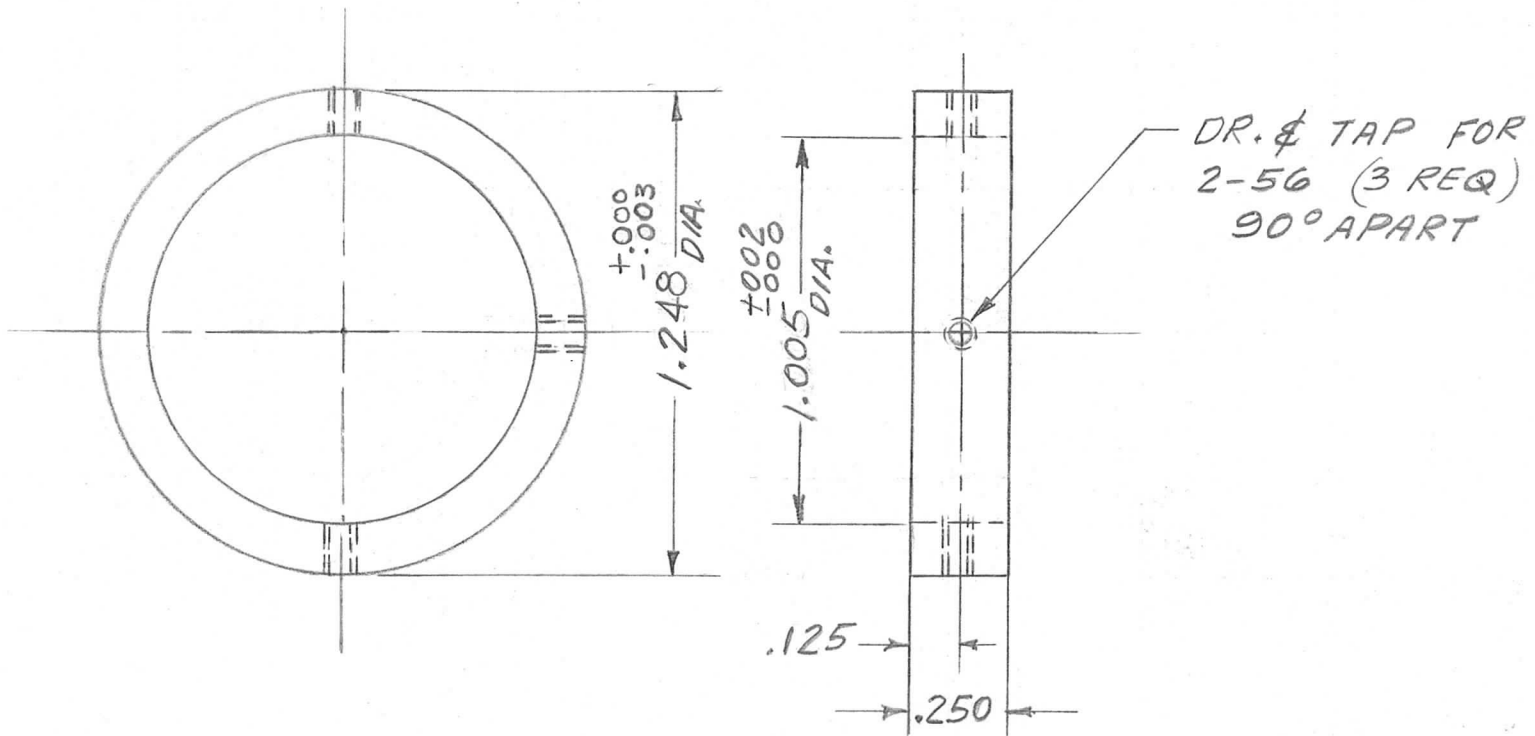

NOTE :
REMOVE ALL BURRS AND SHARP EDGES

A	1.005 DIA. WAS 1.000 DIA	1/2/69	19170	K.H.	J.D.	FB	REQ. ITEM	PART NO.	0. POSE	DESCRIPTION	SYMBOL		
Ø	ORIGINAL RELEASE FOR PRODUCTION	4.9.65	Ø	J.S.				1/4 THK		THE TECHNICAL MATERIEL CORP. MAMARONECK, NEW YORK			
XI	DIM. 1.248 WAS 1.250	12-2-64		GDL				STOCK SIZE					
X	1.000 DIA. WAS .750	10/28/64						ALUMINUM		BUSHING, DIAL MTG			
SYM	DESCRIPTION	DATE	CH. NO.	DRAFTS	CHECKER	ENG. APP.		MATERIAL		(RIGHT)			
UNLESS OTHERWISE SPECIFIED DIMENSIONS ARE IN INCHES AND INCLUDE CHEMICALLY APPLIED OR PLATED FINISHES		SCALE						5052-H32		D.A.C.	@	<i>[Signature]</i>	
		2:1						TYPE & TEMPER	HEAT TREAT. SPEC.	DRAWN	CHECKED	FINAL APPROVAL	
DECIMALS X ± .05 .XX ± .01 .XXX ± .005		FRACTIONS ± 1/64 ANGLES ± 0° 30'		CODE				5404 YELLOW IRIDITE			<i>[Signature]</i>	PM1131	A
TOLERANCES		A						FINISH & SPEC. NO.	ELEC. DES. APP.	MECH. DES. APP.			