

IF IT IS FOUND DESIRABLE TO CHANGE ANY TOLERANCE OR OTHER DETAIL SPECIFIED ON THIS DRAWING NOTIFY THE PURCHASER PROMPTLY.

RELEASED

PM-162

MAXIMUM ALLOWABLE TOLERANCES HAVE BEEN DETERMINED AND DEVIATIONS WILL BE CAUSE FOR REJECTION. REMOVE ALL BURRS AND SHARP EDGES

USED ON

MODEL	PROJECT NO.	ASS'Y. NO.	DATE
EPP	162	A-253	11-12-52

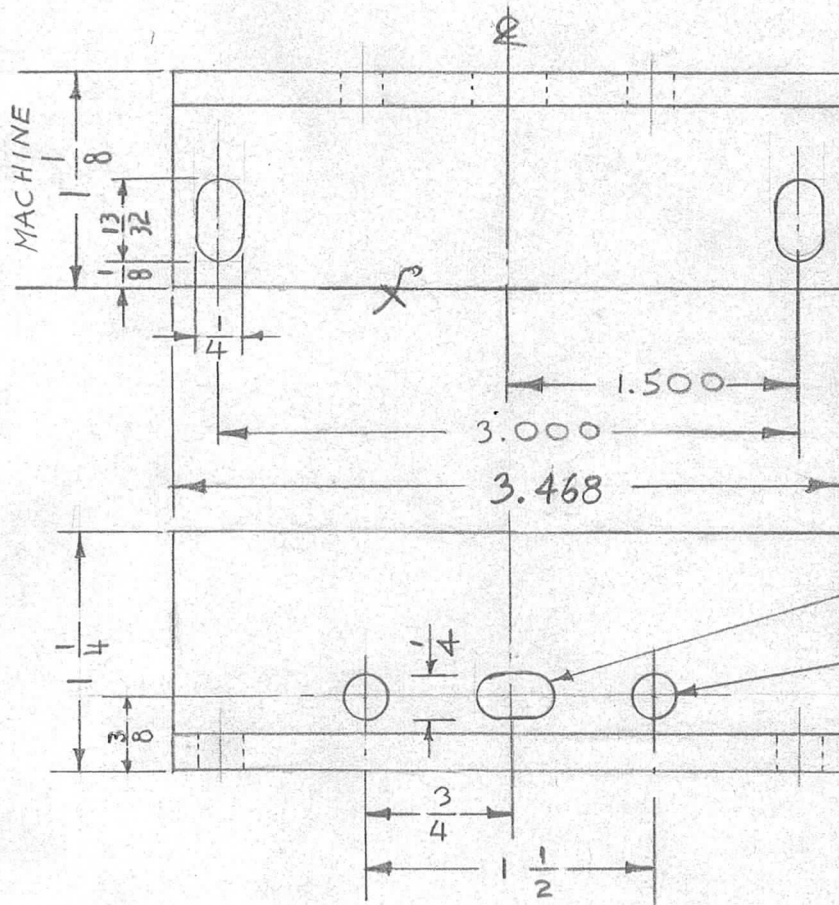

1/4 x 3/8 LONG
1/4 DIA. (.250)

REQ.	ITEM	PART NO.	DESCRIPTION	SYMBOL
			THE TECHNICAL MATERIEL CORP. MAMARONECK. NEW YORK	
			BRACKET, END	
			15 11-12-52	
			DRAWN	ELEC. DES. APP. MECH. DES. APP.
			11/13/52	
			CHECKED	FINAL APPROVAL
				PM-162

ISSUE	ITEM	CHANGED FROM	DATE	CN. NO.	DRAFTS	CHECKER	ENG. APP.

TOLERANCES	SCALE
DEC. DIM. ± .005 FRAC. DIM. ± 1/64 ANGULAR DIM. ±	FULL SIZE

ALL OTHERS	DRILL, PUNCH, COMMERCIAL STOCK SIZES AND MANUFACTURERS TOLERANCES ARE NOT INCLUDED.

TYPE & TEMPER	HEAT TREAT. SPEC.	FINISH & SPEC. NO.
15		S-101, S-114, S-115