

IF IT IS FOUND DESIRABLE TO CHANGE ANY TOLERANCE OR OTHER DETAIL SPECIFIED ON THIS DRAWING NOTIFY THE PURCHASER PROMPTLY.

RELEASED

PM-153

MAXIMUM ALLOWABLE TOLERANCES HAVE BEEN DETERMINED AND DEVIATIONS WILL BE CAUSE FOR REJECTION. REMOVE ALL BURRS AND SHARP EDGES

USED ON

MODEL	PROJECT NO.	ASS'Y. NO.	DATE
TWR-115	151	A-220	9-3-52

TAP 6-32 THD. (2 HOLES)

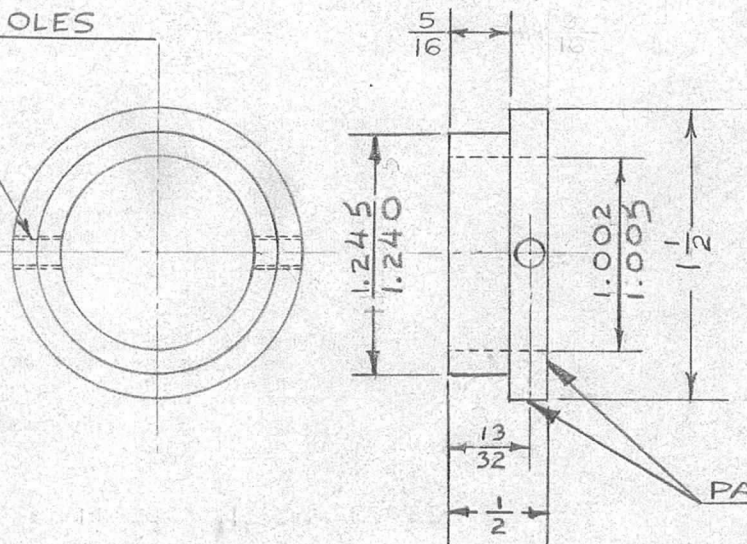

NOTE:

- S-101 (CAUSTIC DIP)
- S-151 (GREY WRINKLE PAINT)

REQ.	ITEM	PART NO.	DESCRIPTION	SYMBOL
		1 1/2 DIA	THE TECHNICAL MATERIEL CORP. MAMARONECK, NEW YORK	
		STOCK SIZE		
		ALUMINUM	POST RING	
		MATERIAL		
		115-T3		
		TYPE & TEMPER		
		HEAT TREAT. SPEC.		
		FINISH & SPEC. NO.		

ISSUE	ITEM	CHANGED FROM	DATE	CN. NO.	DRAFTS	CHECKER	ENG. APP.

TOLERANCES		SCALE FULL SIZE
ALL OTHERS	DEC. DIM. ± .005 FRAC. DIM. ± 1/64 ANGULAR DIM. ±	DRILL, PUNCH, COMMERCIAL STOCK SIZES AND MANUFACTURERS TOLERANCES ARE NOT INCLUDED.

DRAWN	ELEC. DES. APP.	MECH. DES. APP.
<i>Label</i>		<i>0974</i>
<i>JAR</i> 11/14/52		

CHECKED	FINAL APPROVAL
	PM-153

IF IT IS FOUND DESIRABLE TO CHANGE ANY TOLERANCE OR OTHER DETAIL SPECIFIED ON THIS DRAWING NOTIFY THE PURCHASER PROMPTLY.

PM-153

MAXIMUM ALLOWABLE TOLERANCES HAVE BEEN DETERMINED AND DEVIATIONS WILL BE CAUSE FOR REJECTION. REMOVE ALL BURRS AND SHARP EDGES

TWR-115

USED ON

MODEL

PROJECT NO.

ASS'Y. NO.

DATE

TAP 6-32 THD. (2 HOLES)

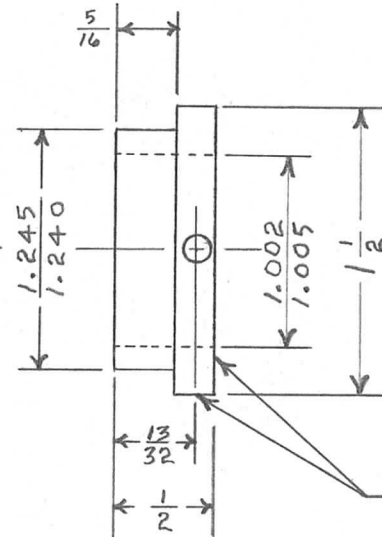
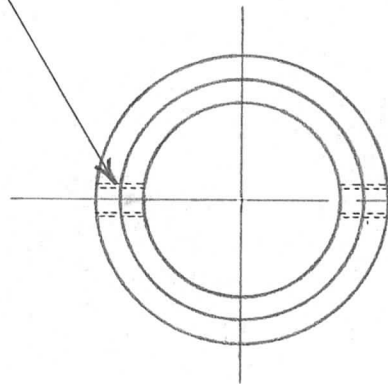

PAINT THESE SURFACES ONLY

NOTE:

1. S-101 (CAUSTIC DIP)
2. S-151 (GREY WRINKLE PAINT)

REQ.	ITEM	PART NO.	DESCRIPTION	SYMBOL
		1/2 DIA	TMC (Canada) LIMITED OTTAWA ONTARIO	
		STOCK SIZE		
		ALUMINUM	POST RING	
		MATERIAL	TAPE WINDING	
		WEIGHT PER PC.		
		115-T3		
		TYPE & TEMPER		
		#		
		HEAT TREAT. SPEC.		
		SEE NOTE		
		FINISH & SPEC. NO.		

ISSUE	ITEM	CHANGED FROM	DATE	CN. NO.	DRAFTS	CHECKER	ENG. APP.

TOLERANCES		SCALE
ALL OTHERS	DEC. DIM. ± .005 FRAC. DIM. ± 1/64 ANGULAR DIM. ±	FULL SIZE

DRAWN		ELEC. DES. APP.	MECH. DES. APP.

CHECKED	FINAL APPROVAL
	<i>Law</i>

PM-153
--------