

REQ. PER UNIT	USED ON			PM1065	A
	MODEL	ASS'Y. NO.	DATE		
1	HFK-2	A-3744	5-5-64		

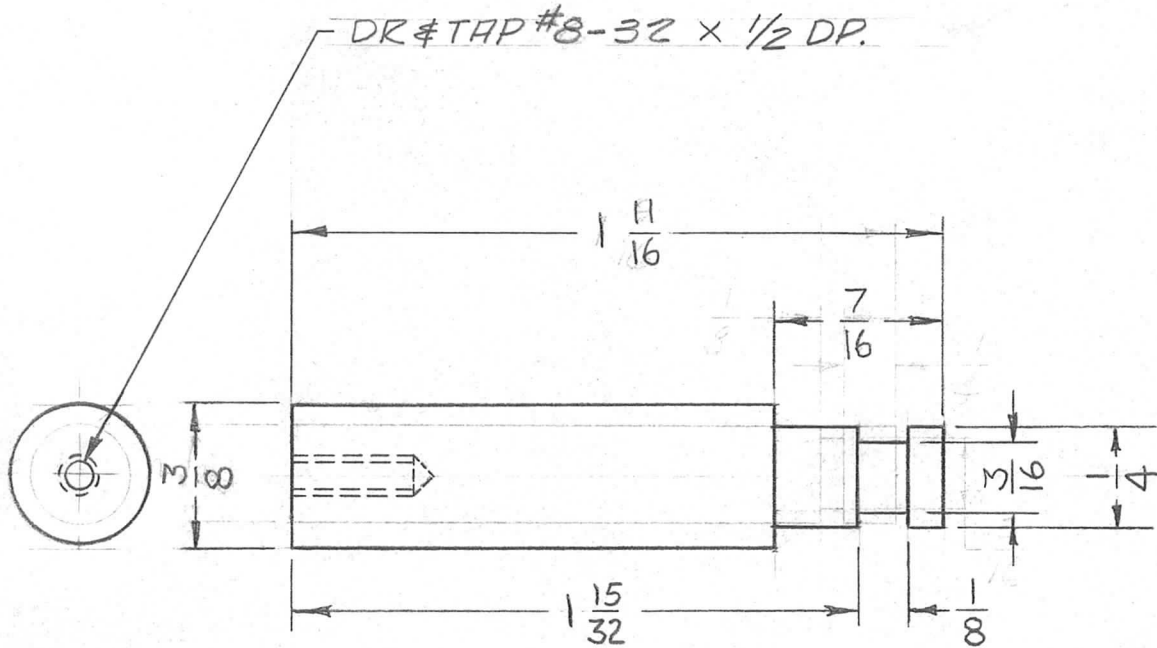

NOTE:
REMOVE ALL BURRS & SHARP EDGES

A	DIM. UPDATED. ASSY. NO. ADD.	10-7-64	12563	J.L.	(a)	Jc										
Ø	ORIGINAL RELEASE FOR PRODUCTION	8-27-64	#	G.D.L.			REQ. ITEM	PART NO.	T. KRUY	DESCRIPTION	SYMBOL					
X2	3/8 DIA. WAS 1/4	8-27-64	#	G.D.L.			STOCK SIZE		THE TECHNICAL MATERIEL CORP. MAMARONECK. NEW YORK							
X1	DRILL & TAP #8-32 WAS #6-32	6-29-64	#	G.D.L.			#303 STAINLESS STEEL		POST, MOUNTING (UNDERCUT)							
X	EXP. RELEASE	5/5/64	#	J.L.			MATERIAL									
SYM	DESCRIPTION	DATE	CH. NO.	DRAFTS	CHECKER	ENG. APP.	TYPE & TEMPER		HEAT TREAT. SPEC.		DRAWN		CHECKED		FINAL APPROVAL	
UNLESS OTHERWISE SPECIFIED DIMENSIONS ARE IN INCHES AND INCLUDE CHEMICALLY APPLIED OR PLATED FINISHES		SCALE		2:1		5104 PASSIVATE		DRAWN		CHECKED		FINAL APPROVAL				
DECIMALS .X ± .05 .XX ± .01 .XXX ± .005		FRACTIONS ± 1/64 ANGLES ± 0° 30'		CODE A		FINISH & SPEC. NO.		ELEC. DES. APP.		MECH. DES. APP.		PM1065		A		