

TMC No.	A	B	C
PL-147-1	15/16	11/16	7/8
PL-147-2	13/16	9/16	7/8

REQ. PER UNIT	USED ON		
	MODEL	ASS'Y. NO.	DATE
			PL-147 A

STANDARD DRAWING

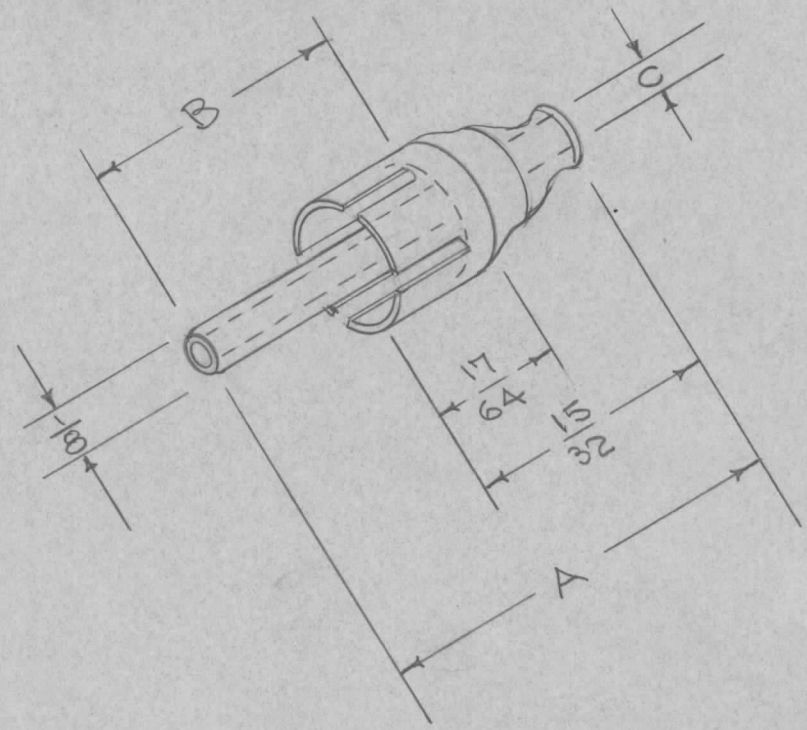

MATERIAL:
 SHELL: BRASS CAD. PLATE
 PIN: BRASS NICKEL PLATE
 WASHER: GRAY FIBER

ISSUE	ITEM	CHANGED FROM	DATE	CH. NO.	DRAFTS	CHECKER	ENG. APP.	REQ. ITEM	PART NO.	DESCRIPTION	SYMBOL				
										THE TECHNICAL MATERIEL CORP. MAMARONECK, NEW YORK					
A	4 3 2	PL-147-3,-4,-5,-6 DELE. CAT. NO COLUMN DELETED MAT'L NOTE ADD., REF. DELE TITLE WAS PLUG TIP	8.4.64	12043	WB	@	JC			PLUG, TIP					
TOLERANCES			SCALE:					MATERIAL		DRAWN					
DEC. DIM. ±			MAXIMUM ALLOWABLE TOLERANCES HAVE BEEN DETERMINED AND ANY DEVIATIONS WILL BE CAUSE FOR REJECTION. REMOVE ALL BURRS AND SHARP EDGES					TYPE & TEMPER		HEAT TREAT. SPEC.		DRAWN			
FRAC. DIM. ±								FINISH & SPEC. NO.		ELEC. DES. APP.		MECH. DES. APP.		FINAL APPROVAL	
ANGULAR DIM. ±														PL-147 A	