

REQ. PER UNIT	USED ON			NP676	Ø
	MODEL	ASS'Y. NO.	DATE		
1	ATS-50-CU-2		8-21-64		

FINISH: REVERSE ETCH ANODIZE ON LUSTER-LESS BLACK BACKGROUND (TYPE 37038) PER FED-STD-595. COLORLESS VARNISH PER MIL-V-6894.

MIN. LETTER SIZE-3/64" HIGH

ORDER AND SERIAL NUMBERS TO BE STEEL STAMPED BY TMC.

NAMEPLATE TO BE IN ACCORDANCE WITH MIL STD-130 AND MIL-M-13231 AND AMENDS.

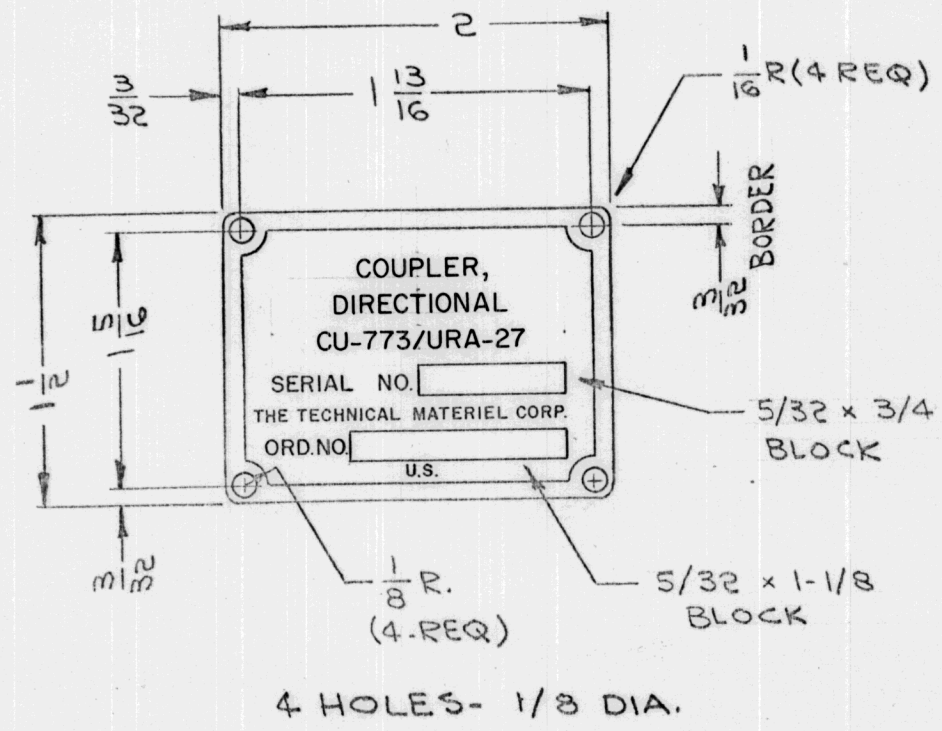

SYM	DESCRIPTION	DATE	CH. NO.	DRAFTS	CHECKER	ENG. APP.	REQ. ITEM	PART NO.	DESCRIPTION	SYMBOL
Ø	ORIGINAL RELEASE FOR PRODUCTION	9-15-64	Ø	J.L.			.032 THK		THE TECHNICAL MATERIEL CORP. MAMARONECK, NEW YORK	
X	EXPER. RELEASE	8-21-64	X	J. Sun			STOCK SIZE		NAMEPLATE, IDENTIFICATION	
							ALUMINUM			
							MATERIAL			
							5052-H32			
							TYPE & TEMPER	HEAT TREAT. SPEC.	DRAWN	CHECKED
							SCALE	1:1		FINAL APPROVAL
							UNLESS OTHERWISE SPECIFIED DIMENSIONS ARE IN INCHES AND INCLUDE CHEMICALLY APPLIED OR PLATED FINISHES			
							DECIMALS	FRACTIONS	CODE	
							X ± .03	± 1/64	A	
							XX ± .01	ANGLES		
							XXX ± .005	± 0° 30'		
							TOLERANCES			
							SEE NOTE			
							FINISH & SPEC. NO.		ELEC. DES. APP.	MECH. DES. APP.
										NP676 Ø