

IF IT IS FOUND DESIRABLE TO CHANGE ANY TOLERANCE OR OTHER DETAIL SPECIFIED ON THIS DRAWING NOTIFY THE PURCHASER PROMPTLY.

NP-109 A

MAXIMUM ALLOWABLE TOLERANCES HAVE BEEN DETERMINED AND DEVIATIONS WILL BE CAUSE FOR REJECTION. REMOVE ALL BURRS AND SHARP EDGES

USED ON

MODEL	PROJECT NO.	ASS'Y. NO.	DATE
DMK-4	140		9-23-52

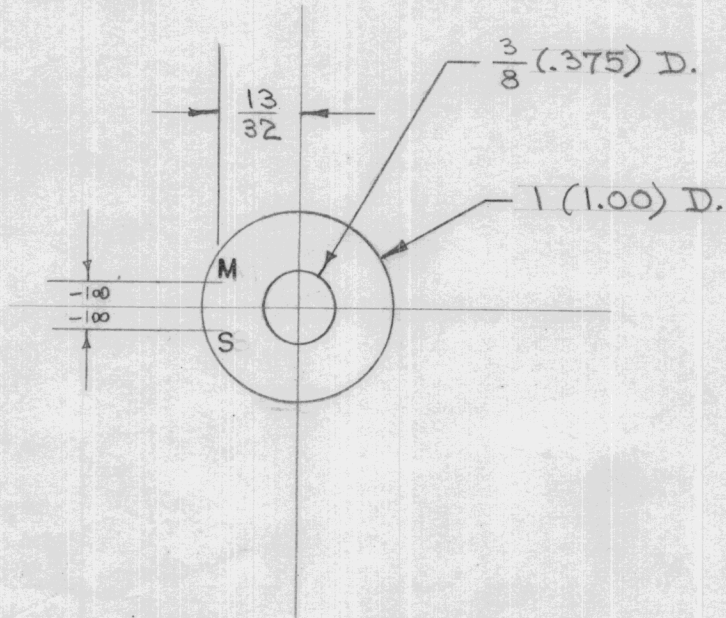

NOTE - FINISH.

- S-101 CAUSTIC DIP
- S-107 ZINC CHROMATE PRIMER
- S-115 SMOOTH GREY ENAMEL

ENGRAVING TO BE 3/32 HIGH, UNFILLED GOTHIC

REQ.	ITEM	PART NO.	DESCRIPTION	SYMBOL
		.032	THE TECHNICAL MATERIEL CORP. MAMARONECK, NEW YORK	
		STOCK SIZE		
		ALUMINUM	NAME PLATE	
		MATERIAL	M-S SWITCH	
		WEIGHT PER PC.		
		TYPE & TEMPER	C.D.D. 9-23-52	
		HEAT TREAT. SPEC.	DRAWN	ELEC. DES. APP.
		FINISH & SPEC. NO.	CHECKED	MECH. DES. APP.
				FINAL APPROVAL
				NP-109 A

A	1	13/32 ADDED	8-1853	1	C.D.D.	JAW	PMS
ISSUE	ITEM	CHANGED FROM	DATE	CN. NO.	DRAFTS	CHECKER	ENG. APP.

TOLERANCES		SCALE	#
ALL OTHERS	DEC. DIM. ± FRAC. DIM. ± ANGULAR DIM. ±	DRILL, PUNCH, COMMERCIAL STOCK SIZES AND MANUFACTURERS TOLERANCES ARE NOT INCLUDED.	