

REQ. PER UNIT 4	USED ON			MS-987	G
	MODEL QDP	ASS'Y. NO.	DATE 8-2-57		

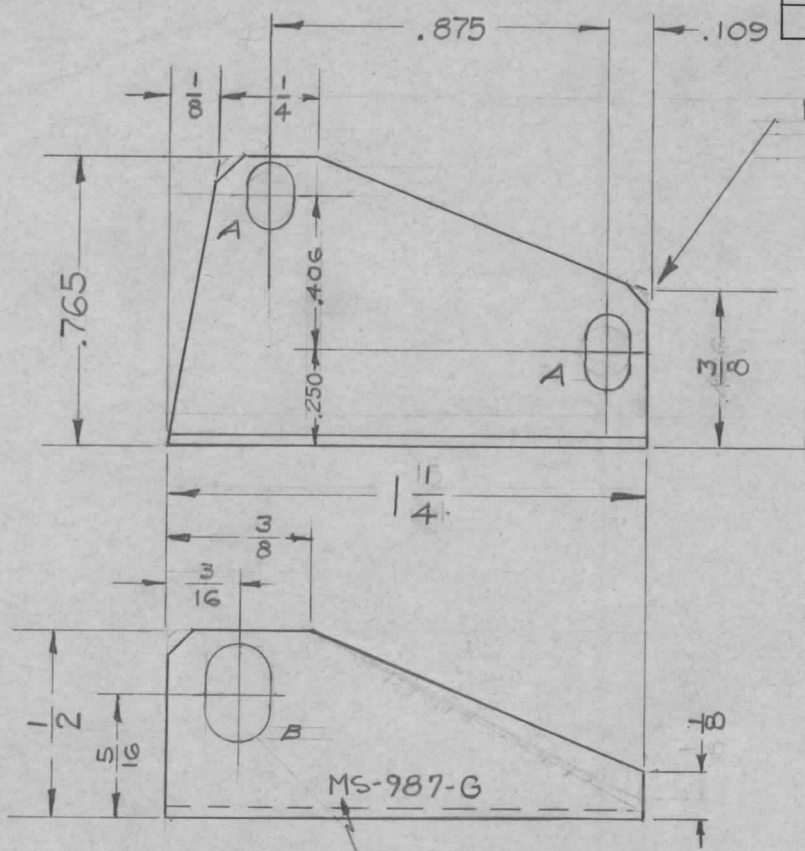

NOTCH  $\frac{1}{16} \times \frac{1}{16}$   
3 REQ

LEGEND  
 A-  $\frac{1}{8} \times \frac{3}{16}$  SLOT 2 REQ.  
 B-  $\frac{3}{16} \times \frac{1}{4}$  1 SLOT REQ.

NOTE  
 S 404 CIRIDITE DIP  
 S-107 LACQUER DIP

NOTICE TO PERSONS RECEIVING THIS DRAWING

THE TECHNICAL MATERIEL CORPORATION claims proprietary right in the material disclosed hereon. This drawing is issued in confidence for engineering information only and may not be reproduced or used to manufacture anything shown hereon without permission from THE TECHNICAL MATERIEL CORPORATION to the user. This drawing is loaned for mutual assistance and is subject to recall at any time.

Property of:

THE TECHNICAL MATERIEL CORPORATION  
 MAMARONECK, NEW YORK

METAL STAMP TMC  
 PART NO. 1/8 HIGH, GOTHIC.

ISSUE	ITEM	CHANGED FROM	DATE	CH. NO.	DRAFTS	CHECKER	ENG. APP.	REQ. ITEM	PART NO.	DESCRIPTION	SYMBOL	
F	1	1/8 DIM. ADDED (BOTTOM)	1-7-65	9528								
E	2	S404 CIRIDITE WAS STOL CABINING DIP	12-8-59	1021								
D	1	1/2 DIA	1/3/58	2								
G	1	$\frac{1}{16} \times \frac{1}{16}$ NOTCHES ADDED	4-26-63	8900		AMY						
TOLERANCES								SCALE:				
DEC. DIM. $\pm .005$			MAXIMUM ALLOWABLE TOLERANCES HAVE BEEN DETERMINED AND ANY DEVIATIONS WILL BE CAUSE FOR REJECTION. REMOVE ALL BURRS AND SHARP EDGES					5052-H32		8-2-57		MS-987
FRAC. DIM. $\pm \frac{1}{64}$								TYPE & TEMPER		HEAT TREAT. SPEC.		
ANGULAR DIM. $\pm 2^\circ$								SEE NOTE				G
								FINISH & SPEC. NO.		ELEC. DES. APP. MECH. DES. APP.		