

IF IT IS FOUND DESIRABLE TO CHANGE ANY TOLERANCE OR OTHER DETAIL SPECIFIED ON THIS DRAWING NOTIFY THE PURCHASER PROMPTLY.

MS-944 | A

MAXIMUM ALLOWABLE TOLERANCES HAVE BEEN DETERMINED AND DEVIATIONS WILL BE CAUSE FOR REJECTION. REMOVE ALL BURRS AND SHARP EDGES

REQ PER UNIT	USED ON			
	MODEL	PROJECT NO.	ASS'Y. NO.	DATE
2	A-1303	271		5/17/56

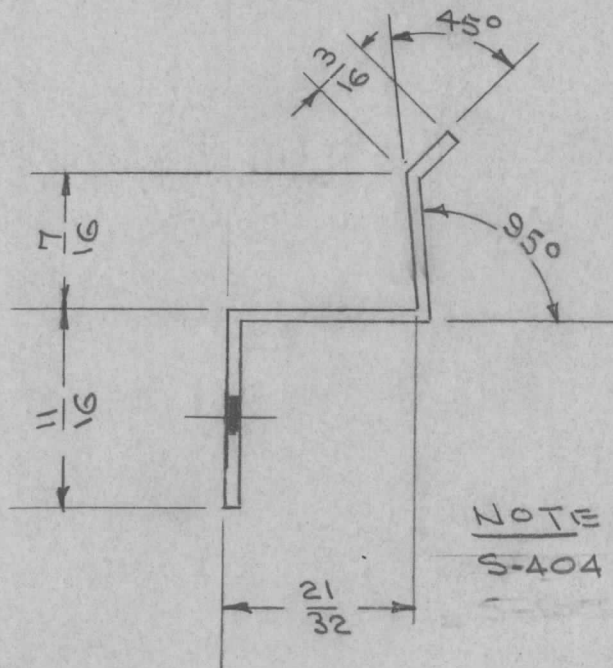
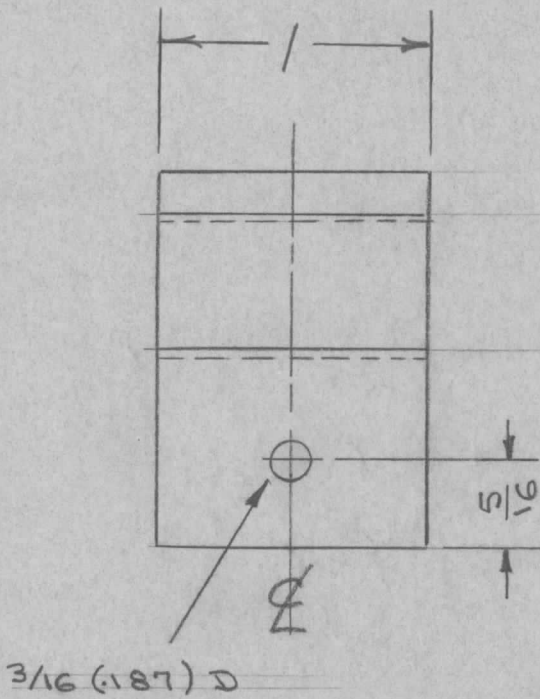

NOTE:  
S-404 IRIDITE

REQ.	ITEM	PART NO.	DESCRIPTION	SYMBOL
		.064	THE TECHNICAL MATERIEL CORP. MAMARONECK, NEW YORK	
		STOCK SIZE		
		ALUMINUM	CLIP, PANEL FASTENING	
		MATERIAL	P/O A-1303	
		WEIGHT PER PC.		
		5052-H32		
		TYPE & TEMPER		
		HEAT TREAT. SPEC.		
		SEE NOTE		
		FINISH & SPEC. NO.		

A	1	S404 IRIDITE WAS S101 CAUSTIC DIP	12-8 59	1001	EP	EMN	
ISSUE	ITEM	CHANGED FROM	DATE	CN. NO.	DRAFTS	CHECKER	ENG. APP.
TOLERANCES			SCALE				
ALL OTHERS	DEC. DIM. $\pm$ FRAC. DIM. $\pm 1/64$ ANGULAR DIM. $\pm$		DRILL, PUNCH, COMMERCIAL STOCK SIZES AND MANUFACTURERS TOLERANCES ARE NOT INCLUDED.				

DRAWN: *Jade*  
 ELEC. DES. APP.: *ME*  
 MECH. DES. APP.: *WZ*  
 CHECKED: *WZ*  
 FINAL APPROVAL: *WZ*

MS-944 | A