

| ZONE | | LTR | | DESCRIPTION | | DATE | | E.M.N. NO | | DRAFT | | CHKD | | APPD | |
|------|----|---------|--|-------------|---|------|--|-----------|--|-------|--|------|--|------|--|
| # | X2 | REDRAWN | | 11-6-67 | 7 | CS | | | | | | | | | |

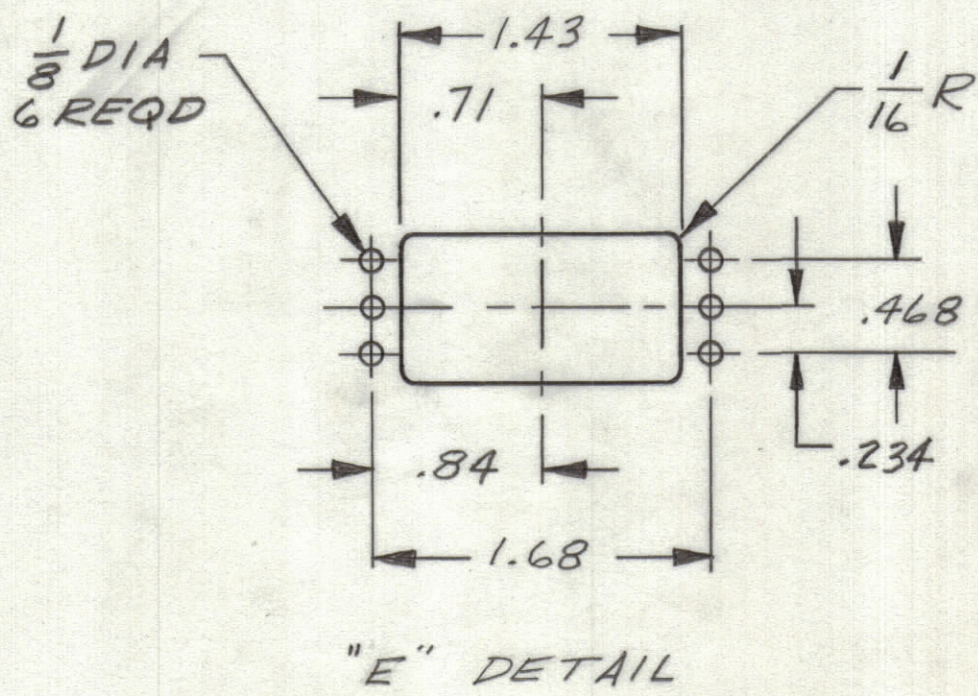
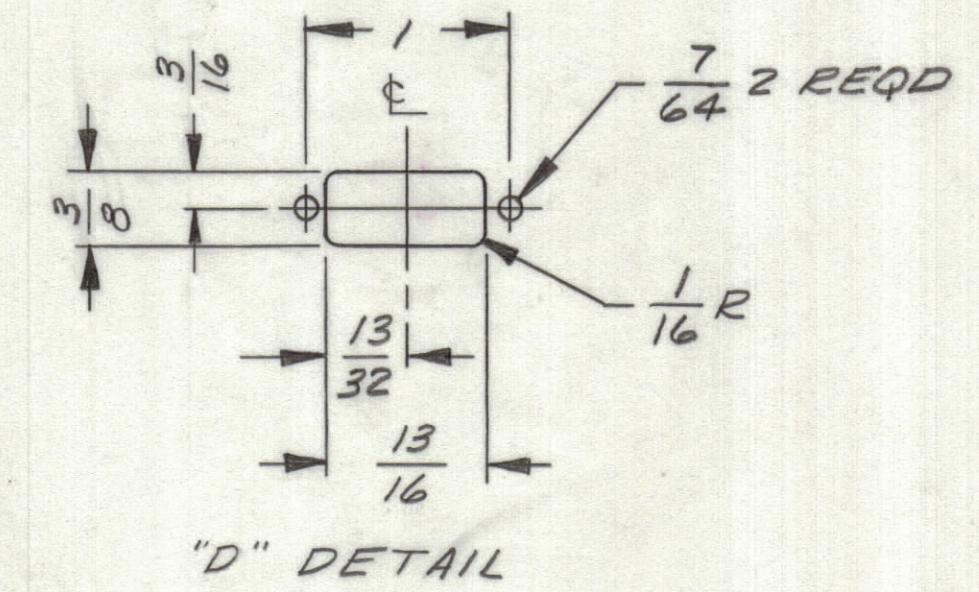
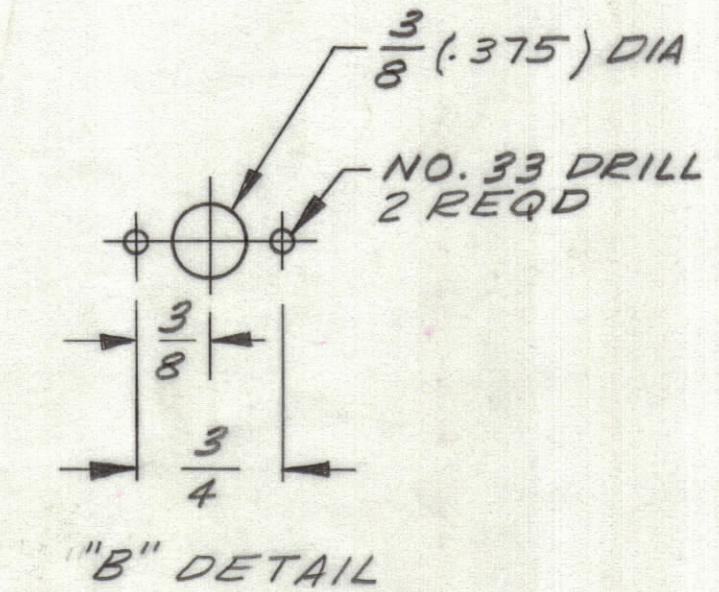
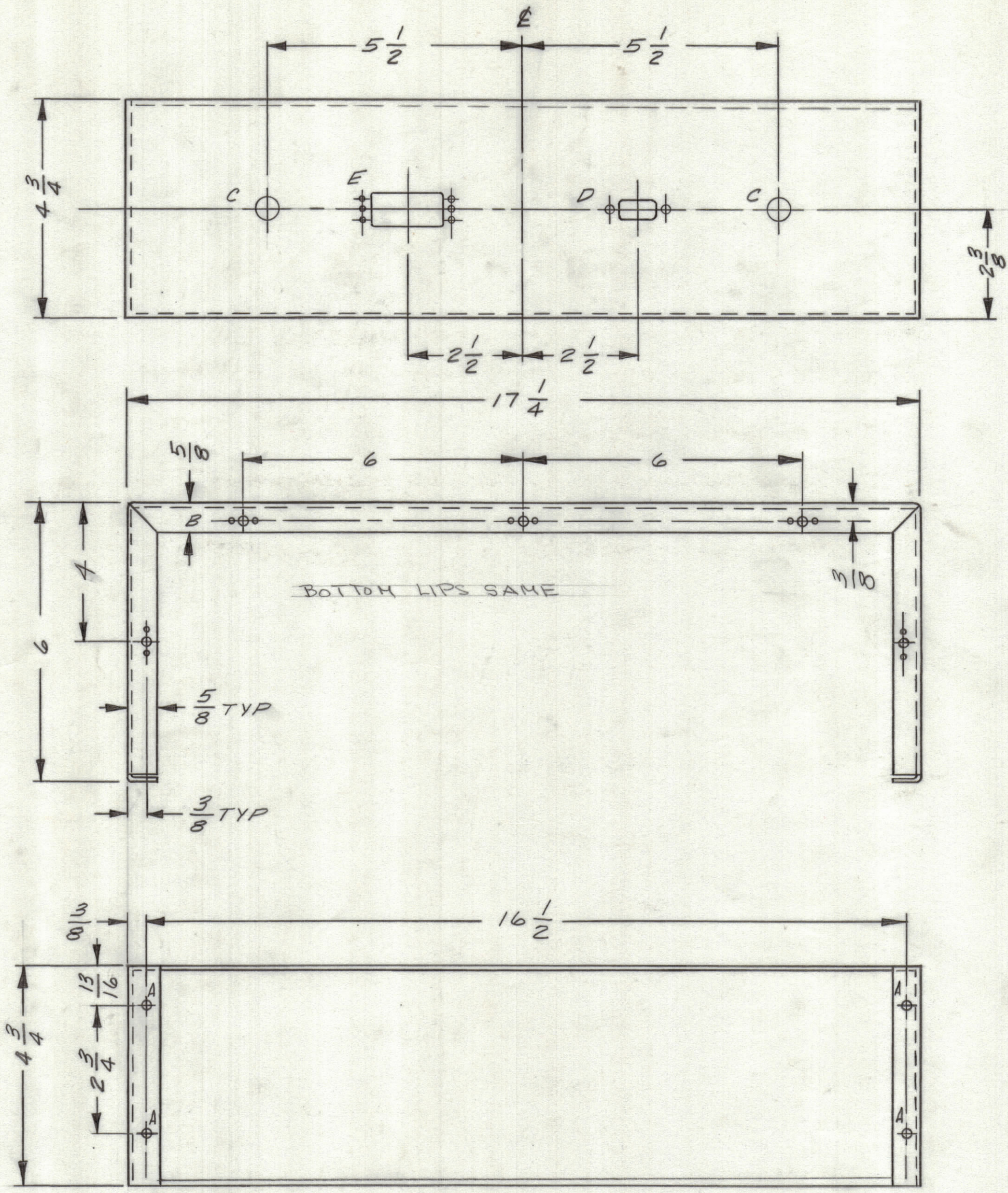

- HOLES:
- A - 3/16 (.187) DIA 4 REQD
 - B - SEE DETAIL 10 REQD
 - C - 11/32 (.344) DIA 2 REQD
 - D - SEE DETAIL 1 REQD
 - E - " 1 REQD

| QTY. REQ. | ITEM | PART NO. | DESCRIPTION | SYMBOL |
|------------------|------|----------|---|---------|
| LIST OF MATERIAL | | | | |
| FINAL APPROVAL | | DATE | THE TECHNICAL MATERIEL CORP. MAMARONECK, NEW YORK WRAPAROUND AVLC-1 | |
| MECH. DES. | | DATE | | |
| ELECT. DES. | | DATE | | |
| CHECKED | | DATE | | |
| DRAWN | | DATE | | |
| MATERIAL | | SIZE | CODE IDENT. NO. | DWG NO. |
| 5052 H32 ALUM | | D | 82679 | MS8038 |
| FINISH | | SCALE | | ISSUE |
| S404 IRIDITE | | | | OF |

| | | |
|--|---------------|-----------|
| 1 | AVLC-1 | |
| QTY / UNIT | MODEL USED ON | ASS'Y NO. |
| APPLICATION | | |
| CODE | | |
| NOTICE TO PERSONS RECEIVING THIS DRAWING | | |
| <small>THE TECHNICAL MATERIEL CORPORATION claims proprietary right in the material disclosed hereon. This drawing is issued in confidence for engineering information only and may not be reproduced or used to manufacture anything shown hereon without permission from THE TECHNICAL MATERIEL CORPORATION to the user. This drawing is loaned for mutual assistance and is subject to recall at any time.</small> | | |

UNLESS OTHERWISE SPECIFIED DIMENSIONS ARE IN INCHES AND INCLUDE CHEMICALLY APPLIED OR PLATED FINISHES

TOLERANCES ON

| | |
|-------------|-----------|
| DECIMALS | FRACTIONS |
| .X ± .05 | ± 1/64 |
| .XX ± .01 | ANGLES |
| .XXX ± .005 | ± 0°-30' |