

IF IT IS FOUND DESIRABLE TO CHANGE ANY TOLERANCE OR OTHER DETAIL SPECIFIED ON THIS DRAWING NOTIFY THE PURCHASER PROMPTLY.

MAXIMUM ALLOWABLE TOLERANCES HAVE BEEN DETERMINED AND DEVIATIONS WILL BE CAUSE FOR REJECTION. REMOVE ALL BURRS AND SHARP EDGES

MS-619 G

TMC NO.	MATERIAL	FINISH
MS-619	SOFT STEEL HOT ROLLED	CADMIUM PLATE S105, IRIDITE S106
MS-619-1	STAINLESS (TYPE 304) STEEL	PASSIVATE S104

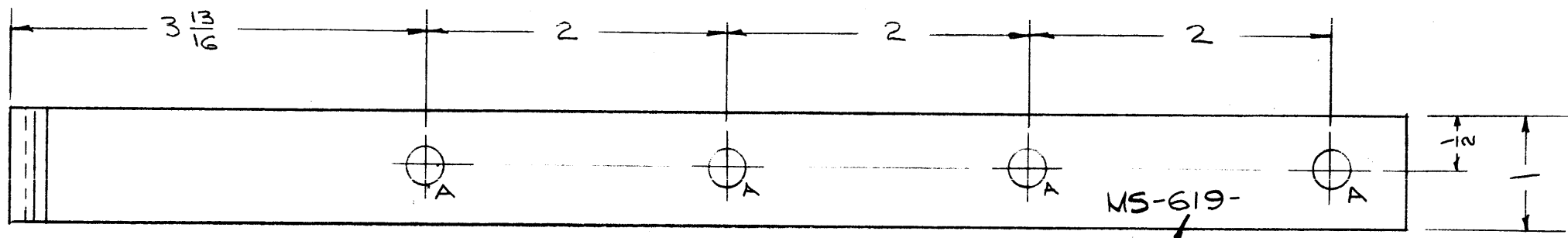

METAL STAMP
TMC PART NO., WITH LATEST REV. LETTER
1/8 GOTHIC AS SHOWN.

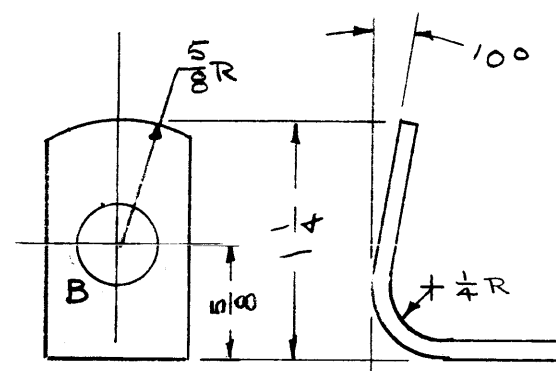

HOLES

- A - 9/32 DIA - 4 REQ.
- B - 13/32 DIA - 1 REQ.

THIS DOCUMENT HAS BEEN PURCHASED BY THE GOVERNMENT AND MAY BE REPRODUCED AND USED IN CONNECTION WITH ANY GOVERNMENT PROCUREMENT OR MAINTENANCE OPERATION

ISSUE	ITEM	CHANGED FROM	DATE	CN. NO.	DRAFTS	CHECKER	ENG. APP.
G	3	DNMS-619-1 FINISH WAS NONE ON MS-619 ADD. IRIDITE S106 "FINISH" COLUMN WAS "PLATING" COL.	7.17.64	11883	LSB	@	MMK
F	3	"B" HOLE ADDED TO LEGEND	7-17-63	9591	W.	W.	W.
	2	PROPERTY STAMP DELETED					
	1	TOLERANCES ADDED					

TOLERANCES	SCALE:
DEC. DIM. ± .005	DRILL, PUNCH, COMMERCIAL STOCK SIZES AND MANUFACTURERS TOLERANCES ARE NOT INCLUDED.
FRAC. DIM. ± 1/64	
± .0030'	

REQ. PER UNIT	MODEL	PROJECT NO.	ASS'Y. NO.	DATE
4	TRC-3500			6-16-58
4	BAC-1-5-20			
4	BAC-1			
4	VRA-1, VRA-2			2-11-55

REQ.	ITEM	PART NO.	DESCRIPTION	SYMBOL
		1/8 x 1	THE TECHNICAL MATERIEL COMP.	
		STOCK SIZE	MAMARONECK. NEW YORK	
		SEE CHART	BRACKET, MOUNTING	
		MATERIAL		
		WEIGHT PER PC.		
		SEE CHART		
		TYPE & TEMPER		
			DATE 2-11-55	
			APB	WOC
			DRAWN	ELEC. DES. APP.
				MECH. DES. APP.
			CHECKED	FINAL APPROVAL
				MS-619 AG

USED ON