

IF IT IS FOUND DESIRABLE TO CHANGE ANY TOLERANCE OR OTHER DETAIL SPECIFIED ON THIS DRAWING NOTIFY THE PURCHASER PROMPTLY.

MS-576 C

MAXIMUM ALLOWABLE TOLERANCES HAVE BEEN DETERMINED AND DEVIATIONS WILL BE CAUSE FOR REJECTION. REMOVE ALL BURRS AND SHARP EDGES

REQ PER UNIT	USED ON			
	MODEL	PROJECT NO.	ASS'Y. NO.	DATE
1	RSC-2	170		12-17-54
4	QDP			8-8-57

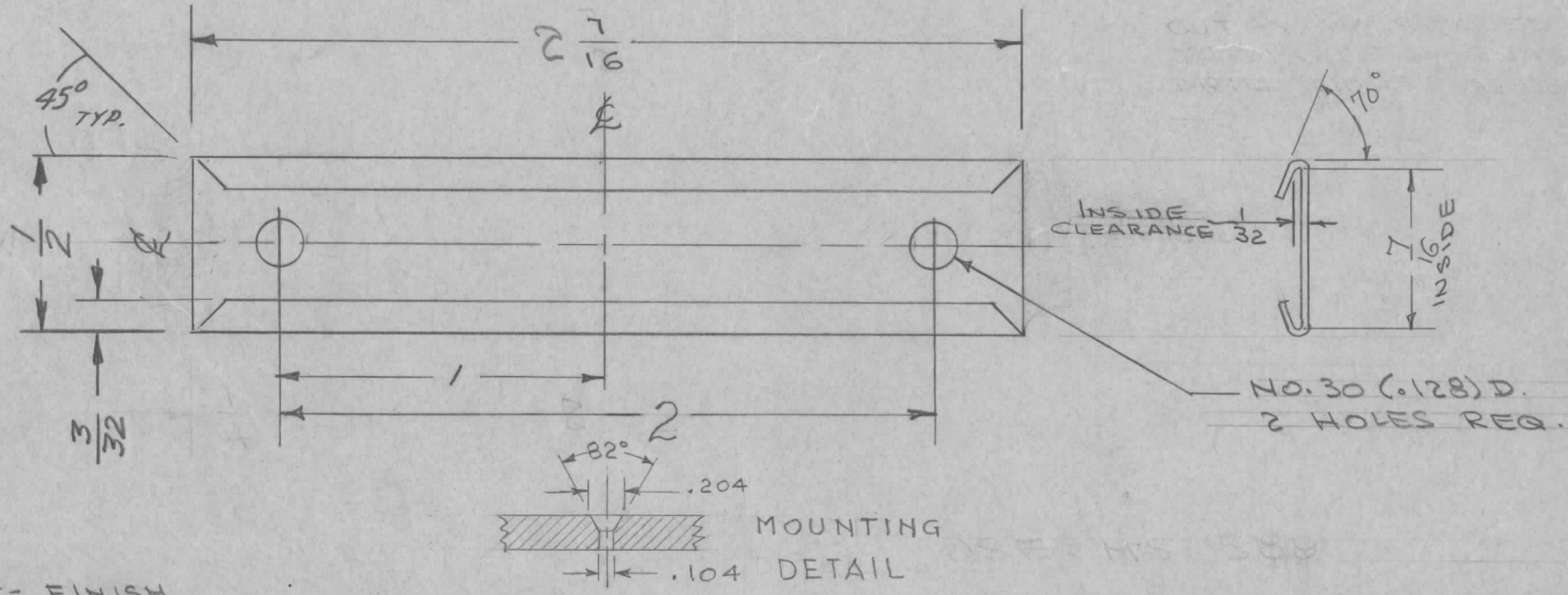

NOTE- FINISH
 CLEAN
 S-114 ZINC CHROMATE PRIMER
 S-115 SMOOTH GRAY ENAMEL
 OR PRIME & PAINT TO
 CUSTOMERS SPECIFICATION.

ISSUE	ITEM	CHANGED FROM	DATE	CN. NO.	DRAFTS	CHECKER	ENG. APP.
C	2	Material Added	10/8/57	3	JMQ	JMQ	[Signature]
B	1	REF: MS-589 Deleted	12-30-54	2	R.B.	ESD	[Signature]
A	1	2 7/16 WAS 2 1/2 DIM. CHANGED	12/17/54	1	ESD	JMQ	[Signature]

TOLERANCES		SCALE
ALL OTHERS	DEC. DIM. ± FRAC. DIM. ± ANGULAR DIM. ± .04	DRILL, PUNCH, COMMERCIAL STOCK SIZES AND MANUFACTURERS TOLERANCES ARE NOT INCLUDED.

REQ.	ITEM	PART NO.	DESCRIPTION	SYMBOL
		.012	THE TECHNICAL MATERIEL CORP. MAMARONECK, NEW YORK	CARD HOLDER
		STOCK SIZE		
		BRASS		
		MATERIAL	WEIGHT PER PC.	
		TYPE & TEMPER	C.D.D. 12-17-54	
		HEAT TREAT. SPEC.	DRAWN	ELEC. DES. APP. MECH. DES. APP.
		SEE NOTE	CHECKED	FINAL APPROVAL
		FINISH & SPEC. NO.		MS-576 C