

REQ. PER UNIT	USED ON			MS 4819 \emptyset
	MODEL	ASS'Y. NO.	DATE	
2	CDN-3		2-4-66	

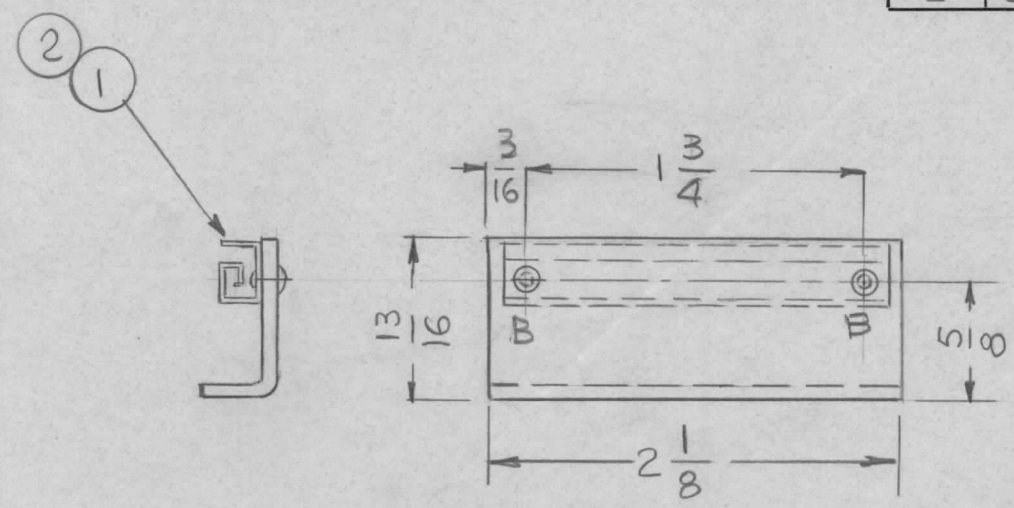

HOLE	DESCRIPTION	REQ
A	9/64 DIA	2
B	.067 DIA.	2

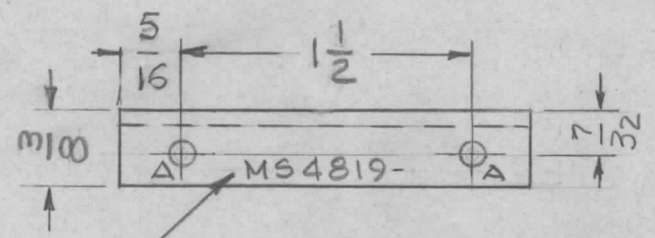

METAL STAMP TMC P/NO. 1/8 HIGH GOTHIC WITH LATEST REV. LETTER

- UNLESS OTHERWISE SPECIFIED:
1. USE MATERIAL THICKNESS FOR MAXIMUM RADIUS ON ALL BENDS
 2. ALL ANGULAR BENDS 90 DEGREES
 3. REMOVE ALL BURRS AND SHARP EDGES
 4. MOUNT INSERTS AFTER FINISHING

1	2	CU157-2	RET., PC. BOARD	A
2	1	EY100-5	EYELET, MTL	A
REQ. ITEM	PART NO.		DESCRIPTION	SYMBOL
.063 THK			THE TECHNICAL MATERIEL CORP.	
STOCK SIZE			MAMARONECK, NEW YORK	
ALUMINUM			BRACKET, MTG, P.C. CARD	
MATERIAL				
5052-H32		G.D.L	QCS	M/M/H
TYPE & TEMPER	HEAT TREAT. SPEC.	DRAWN	CHECKED	FINAL APPROVAL
8A04 YEL. IRIDITE			DL	MS 4819 \emptyset
FINISH & SPEC. NO.		ELEC. DES. APP.	MECH. DES. APP.	

SYM	DESCRIPTION	DATE	CH. NO.	DRAFTS	CHECKER	ENG. APP.
\emptyset	ORIGINAL RELEASE	2/3/66				AD
UNLESS OTHERWISE SPECIFIED DIMENSIONS ARE IN INCHES AND INCLUDE CHEMICALLY APPLIED OR PLATED FINISHES		SCALE 1:1				
DECIMALS .X \pm .05 .XX \pm .01 .XXX \pm .005	TOLERANCES	FRACTIONS \pm 1/64 ANGLES \pm 0° 30'	CODE A			