

HOLE	DESCRIPTION	REQ.
A	.203 DIA.	2
B	.375 DIA.	1
C	.312 DIA.	6

REQ. PER UNIT	USED ON		
	MODEL	ASS'Y. NO.	DATE
1	C4GR-3A		10-5-65

MS4769  $\emptyset$

UNLESS OTHERWISE SPECIFIED:

1. USE MATERIAL THICKNESS FOR MAXIMUM RADIUS ON ALL BENDS
2. ALL ANGULAR BENDS 90 DEGREES
3. REMOVE ALL BURRS AND SHARP EDGES

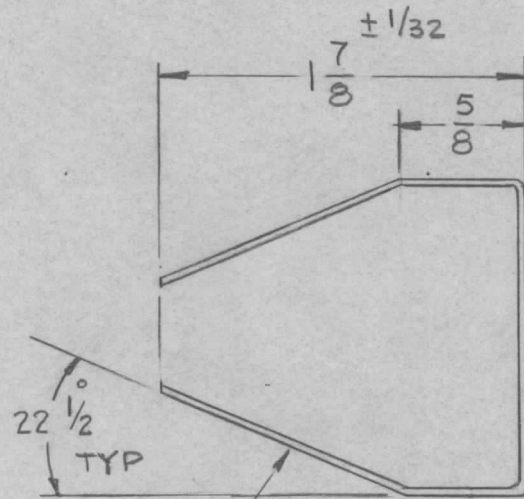

RUBBER STAMP TMC PT/No. 1/8 HIGH  
GOTHIC W/LATEST REV. LETTER

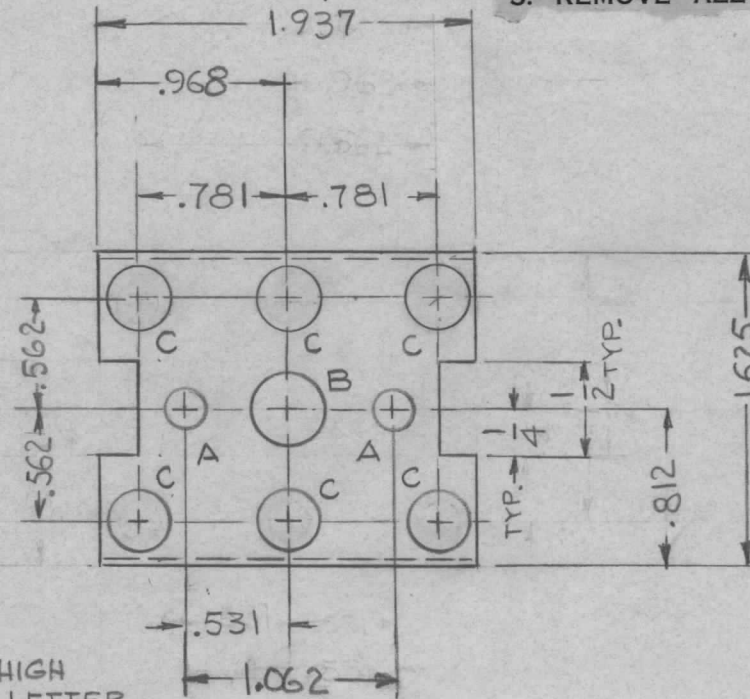

REQ.	ITEM	PART NO.	J. ANGER		DESCRIPTION	SYMBOL
		.031 THK.			THE TECHNICAL MATERIEL CORP. MAMARONECK. NEW YORK	$\emptyset$
		STOCK SIZE				
		ALUMINUM			SHIELD, RF	
		MATERIAL				
		5052-H32	G.D.L. 10-5-65			
		TYPE & TEMPER	HEAT TREAT. SPEC.	DRAWN	CHECKED	FINAL APPROVAL
		5404 YEL. IRIDITE				
		FINISH & SPEC. NO.	ELEC. DES. APP.	MECH. DES. APP.		
					MS4769	$\emptyset$