

| | | | | | |
|---------------|---------|------------|---------|---------|---|
| REQ. PER UNIT | USED ON | | | MS 4505 | Ø |
| | MODEL | ASS'Y. NO. | DATE | | |
| 1 | RFTA-1 | A 4286 | 4-13-65 | | |

HOLE ~
13/64 DIA.

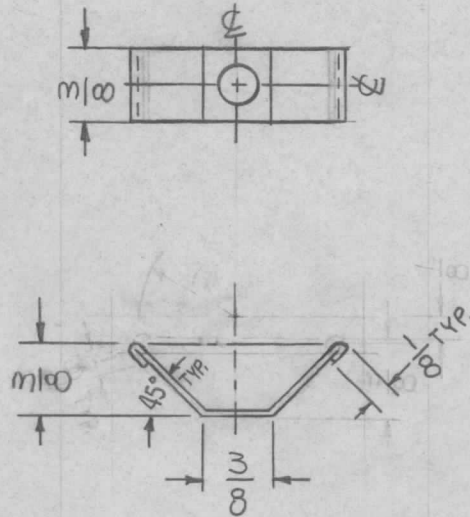

NOTE:
HEAT TREAT 600° F FOR 3
HOURS THEN AIR COOL.

| REQ. ITEM | PART NO. | F. BUDETTI DESCRIPTION | SYMBOL |
|---|---------------------------------|---|----------------------------------|
| Ø | ORIGINAL RELEASE FOR PRODUCTION | 5/19/66 | Ø CV |
| X2 | HEAT TREAT NOTE ADDED | 5-24-65 | X2 SRG |
| X1 | 3/8 HIGH WAS 5/16 | 4-26-65 | X1 SRG |
| SYM | DESCRIPTION | DATE | CH. NO. DRAFTS CHECKER ENG. APP. |
| UNLESS OTHERWISE SPECIFIED DIMENSIONS ARE IN INCHES AND INCLUDE CHEMICALLY APPLIED OR PLATED FINISHES | | SCALE | 1:1 |
| DECIMALS .X ± .05 .XX ± .01 .XXX ± .005 | TOLERANCES | FRACTIONS ± 1/64 ANGLES ± 0° 30' | CODE A |
| | SEE NOTE | SRG | QC/S 203 |
| TYPE & TEMPER | HEAT TREAT. SPEC. | DRAWN | CHECKED |
| S245 SILVER PLATE | | AA 6/14/66 | BB |
| S423 IRIDITE 18-P SILVER KOTE | | | |
| FINISH & SPEC. NO. | ELEC. DES. APP. | MECH. DES. APP. | MS 4505 Ø |

THE TECHNICAL MATERIEL CORP.
MAMARONECK, NEW YORK
CONTACT, ELECTRICAL