

REVISIONS							
ZONE	SYM	DESCRIPTION	DATE	E.M.N. NO.	DRAFT	CHKD	APPD
	X	EXPER. RELEASE	2-19-65		HLL		
	Ø	ORIGINAL RELEASE FOR PRODUCTION					
	A	B HOLE, 4 C HOLES ADDED	5-12-64	14059	CJL	JCS	CJS

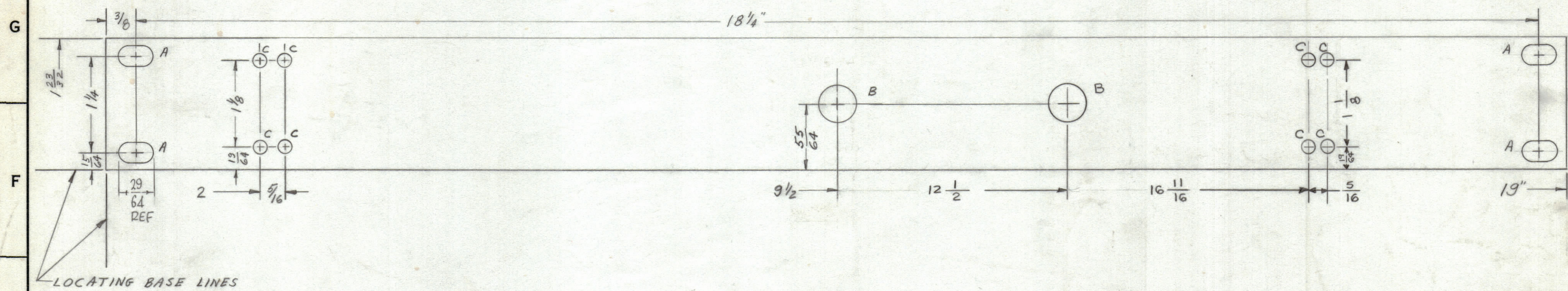

HOLE LEGEND		
HOLE	DESCRIPTION	REQD
A-	29/64 X 1/4 SLOT	4 REQ
B-	15/32 DIA	2 REQ
C-	9/64 DIA.	8 REQ

METAL STAMP TMC PART NO. 1/8
HIGH GOTHIC ON REAR OF PANEL
W/LATEST REVISION LETTER

FINISH NOTES:
1. S404 - IRIDITE 14-2 AL-COAT.
2. S114 - ZINC CHROMATE PRIMER } FRONT AND
3. S115 - SMOOTH GRAY ENAMEL } EDGES ONLY

MACHINING:
1. MILL ALL EDGES.
2. HOLES MUST BE DRILLED, UNLESS OTHERWISE SPECIFIED.
3. LATERAL BOW OF PANEL MUST BE KEPT TO .031 TOLERANCE.
4. PANEL MUST BE FREE OF ALL MACHINING MARKS, GOUGES AND SCRATCHES. IF NECESSARY, SAND FRONT OF PANEL WITH NO. 120 GRIT SANDPAPER.

NOTES

Q'TY./UNIT	MODEL USED ON	ASSY. NO.
1	AX 560	A2590

REF: LD1787

REQ'D	ITEM	PART NUMBER	DESCRIPTION	SYMBOL
B.N.A.P. LIST OF MATERIAL				
MATERIAL		THE TECHNICAL MATERIEL CORP.		
3/16 ALUMINUM		MAMARONECK, NEW YORK		
2024-T3		TITLE		
FINISH		MACHINING, FRONT PANEL		
SEE NOTES		DRAWN		
UNLESS OTHERWISE SPECIFIED		DATE		
DIMENSIONS ARE IN INCHES AND INCLUDE		DATE		
CHEMICALLY APPLIED OR PLATED FINISHES		DATE		
DECIMALS		ELECT. DES.		
.X ± .05		DATE		
.XX ± .01		DATE		
.XXX ± .005		DATE		
TOLERANCES		MECH. DES.		
FRACTIONS		DATE		
± 1/64		DATE		
ANGLES		DATE		
± 0° 30'		DATE		

MS4387

REV. LTR. A