

MS4287 Ø

REVISIONS

SYM	DESCRIPTION	DATE	E.M.N. NO.	DRAFT	CHKD	APPD
X1	REDRAWN & REVISED	6-22-65		G.D.L		
Ø	ORIGINAL RELEASE FOR PRODUCTION	7-26-67	Ø	CV		<i>Joe</i>

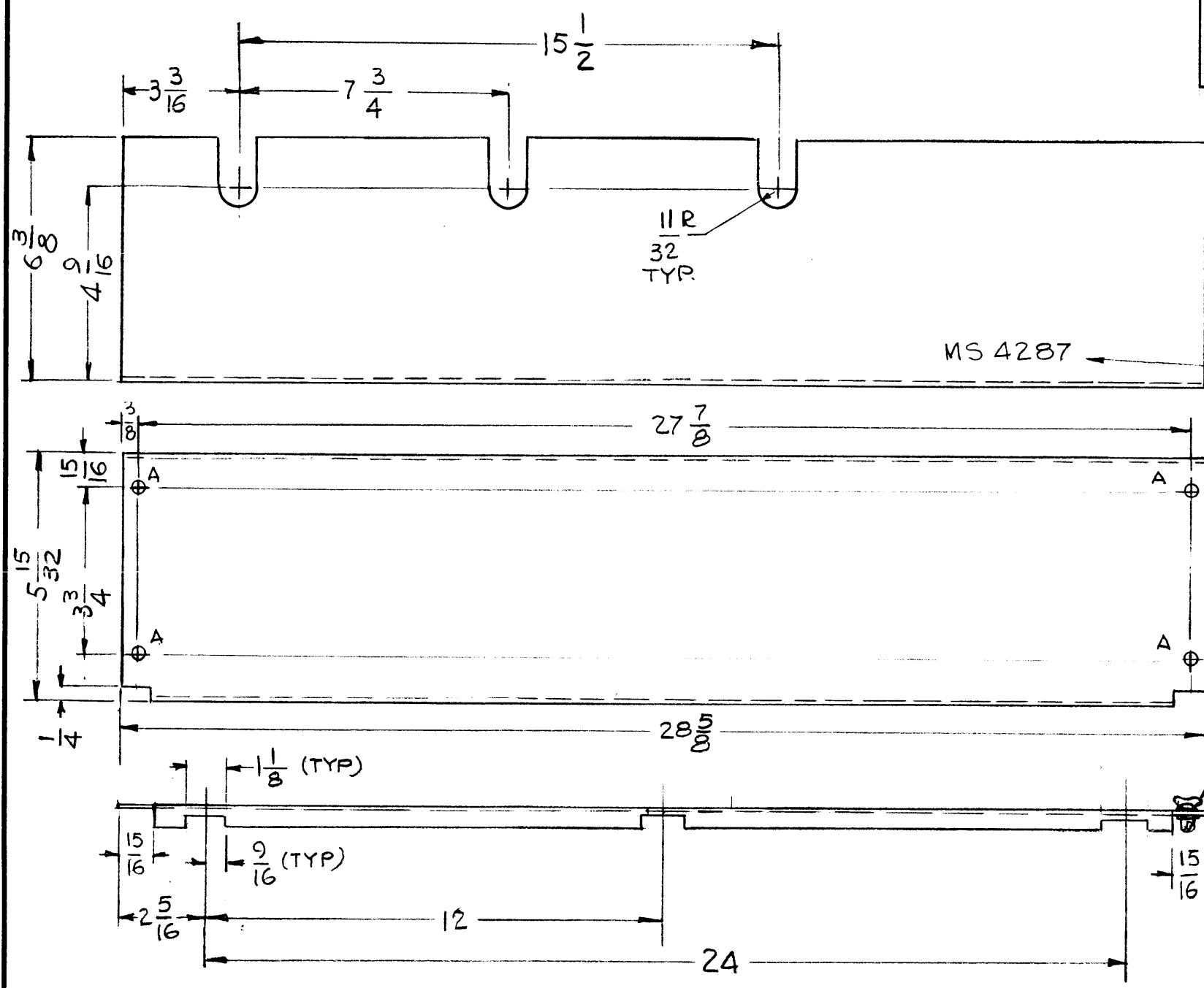

HOLE	DESCRIPTION	REQ
A	1/4 DIA	4

METAL STAMP TMC P/No. 1/8 HIGH GOTHIC WITH LATEST REV. LETTER

NOTE: HARDWARE TO BE SUPPLIED AND ASSEMBLED BY TMC

UNLESS OTHERWISE SPECIFIED:

1. USE MATERIAL THICKNESS FOR MAXIMUM RADIUS ON ALL BENDS
2. ALL ANGULAR BENDS 90 DEGREES
3. REMOVE ALL BURRS AND SHARP EDGES

NOTES

REQ'D.	ITEM	PART NUMBER	DESCRIPTION	SYMBOL
4	2	FS 109 - 3	RING, RETAINING	
4	1	FS 103 - 3	STUD, TURNLOCK, WING	

F. BUDETTI		LIST OF MATERIAL	
MATERIAL .064 THK ALUMINUM 5052 - H32		THE TECHNICAL MATERIEL CORP. MAMARONECK, NEW YORK	
FINISH S404 YEL. IRIDITE		TITLE COVER, SHIELD, R.F	
UNLESS OTHERWISE SPECIFIED DIMENSIONS ARE IN INCHES AND INCLUDE CHEMICALLY APPLIED OR PLATED FINISHES		DRAWN G.D.L	DATE 4/25/67
		CHECKED	DATE
		ELECT. DES.	DATE
		MECH. DES. <i>Joe</i>	DATE 7/26/67
		MS4287	
		SHEET	REV. LTR.

1	TST -10K	
Q'TY./UNIT	MODEL USED ON	ASS'Y. NO.
SCALE DO NOT SCALE	CODE A	
THE CONTENTS OF THIS DRAWING ARE THE EXCLUSIVE PROPERTY OF THE TECHNICAL MATERIEL CORP. ITS UNAUTHORIZED USE OR REPRODUCTION IN WHOLE OR IN PART IS STRICTLY FORBIDDEN.		

DECIMALS .X ± .05 .XX ± .01 .XXX ± .005	TOLERANCES	FRACTIONS ± 1/64 ANGLES ± 0° 30'
---	------------	----------------------------------