

UNLESS OTHERWISE SPECIFIED:

1. USE MATERIAL THICKNESS FOR MAXIMUM RADIUS ON ALL BENDS
2. ALL ANGULAR BENDS 90 DEGREES
3. REMOVE ALL BURRS AND SHARP EDGES

REQ. PER UNIT	USED ON		MS4032 Ø
	MODEL	ASS'Y. NO.	
1	PFCB-1		

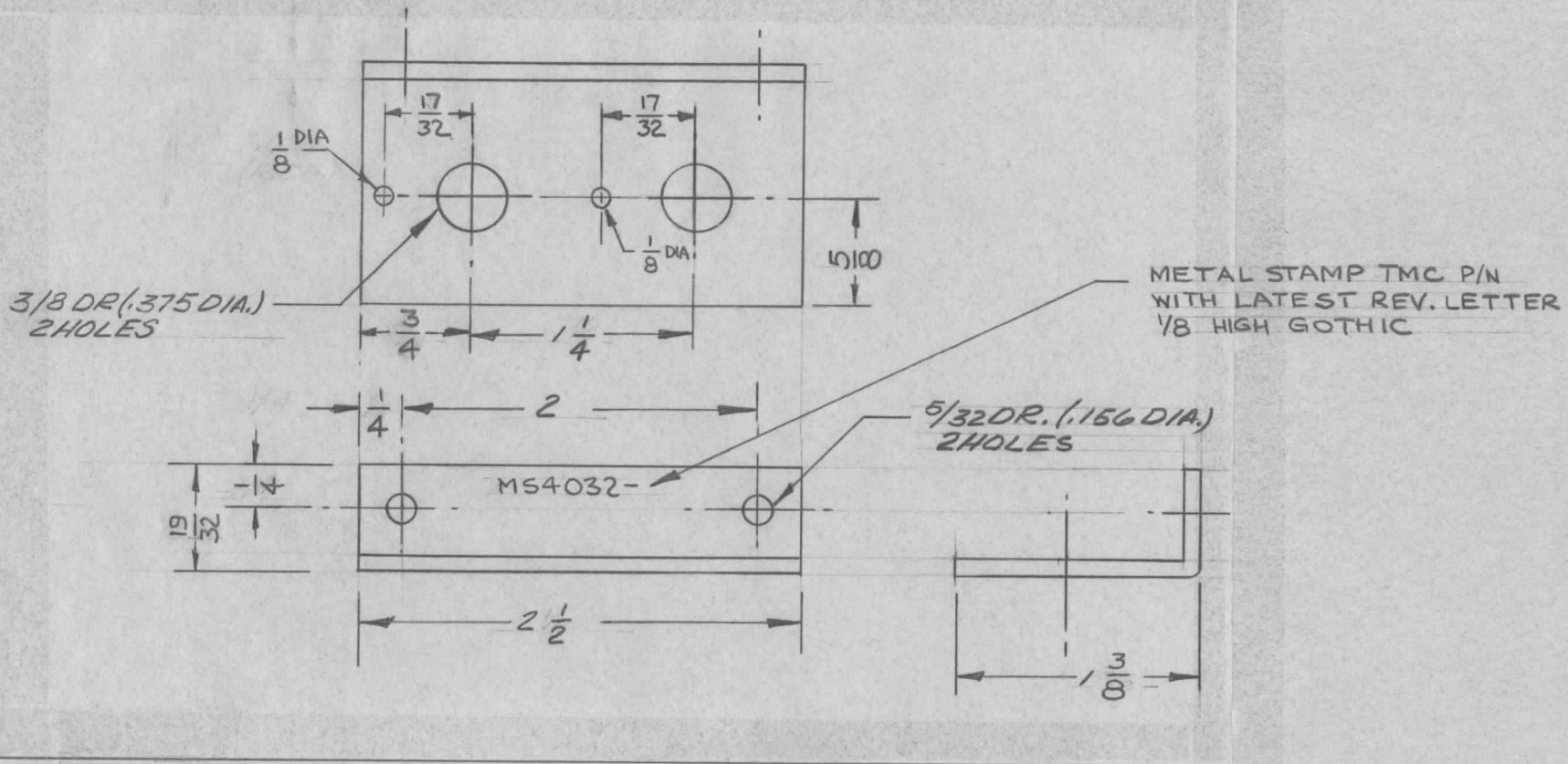

REF: LD 1636

REQ. ITEM	PART NO.	DESCRIPTION	SYMBOL
Ø	ORIGINAL RELEASE FOR PRODUCTION	12.11.64	Ø JL
X	REDRAWN W/CHANGES	10.16.64	X, LB
SYM	DESCRIPTION	DATE	CH. NO. DRAFTS CHECKER ENG. APP.
UNLESS OTHERWISE SPECIFIED DIMENSIONS ARE IN INCHES AND INCLUDE CHEMICALLY APPLIED OR PLATED FINISHES		SCALE	NONE
DECIMALS .X ± .05 .XX ± .01 .XXX ± .005	TOLERANCES	FRACTIONS ± 1/64 ANGLES ± 0° 30'	CODE A
.081 THICK STOCK SIZE		THE TECHNICAL MATERIEL CORP. MAMARONECK, NEW YORK	
ALUMINUM		BRACKET	
MATERIAL		DOPPLER CORRECTOR, POT SUPPORT	
50-52 H32	HEAT TREAT. SPEC.	10.16.64 LB @ J.S.	10-22-64 RBL
YELLOW IRIDITE	FINISH & SPEC. NO.	DRAWN	CHECKED
		FINAL APPROVAL	
		ELEC. DES. APP.	MECH. DES. APP.
		MS4032 Ø	