

LIST OF MATERIAL

ITM	REG	TMC	P/N	DESCRIPTION
1	3	NT129-632-4		NUT, ROUND SWAGE

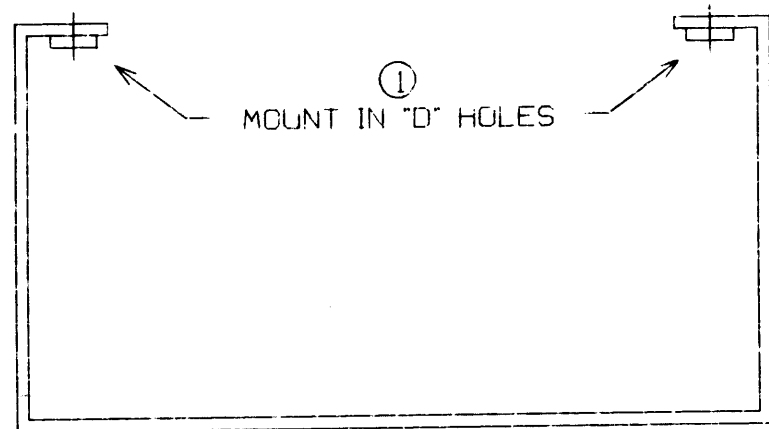

DRAFT	CHKD	LTR	REVISION DESCRIPTION	DATE	APVD	DRAWING	REV
G.D.L.		L	25/64 WAS 7/16-1/2 DIM. ADD.	1-6-93		MS3919	0
G.D.L.		M	DIM. 2 3/32 WAS 3/4 & 1 7/8 WAS 2"	1-13-93			
G.D.L.		N	DIM 11/32 WAS 7/16. HOL. WAS "B" METAL DEL.	1-19-93			

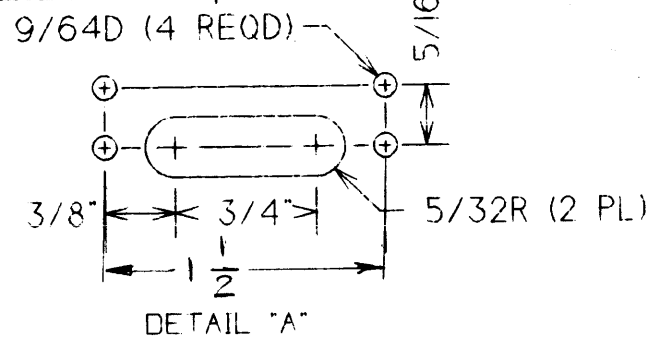

- HOLES:
- A SEE DETAIL
 - B .181 DIA 17 REQD
 - C 1/2 DIA 3 REQD
 - D Ø.191-Ø.194 DIA 3 REQD
 - E 7/32 DIA 3 REQD

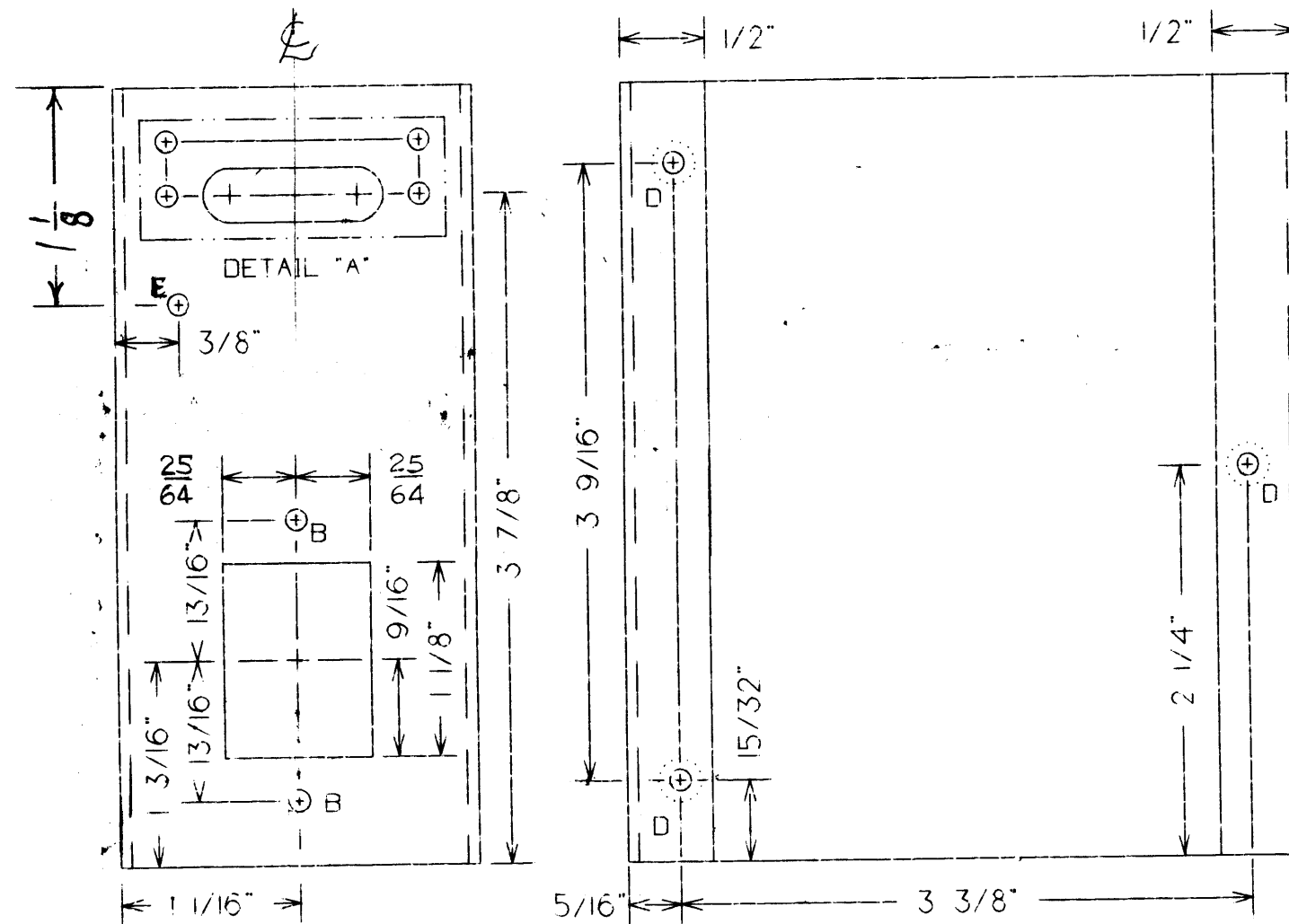
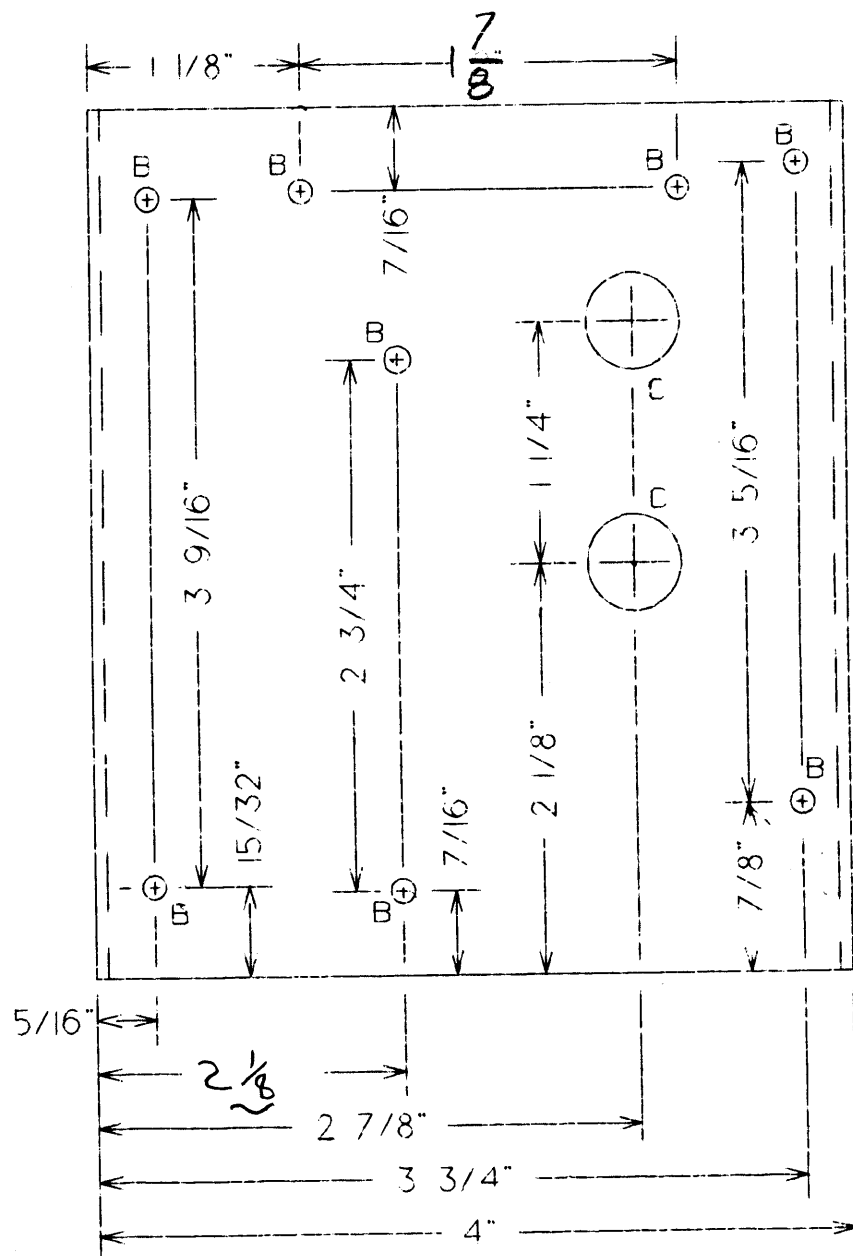
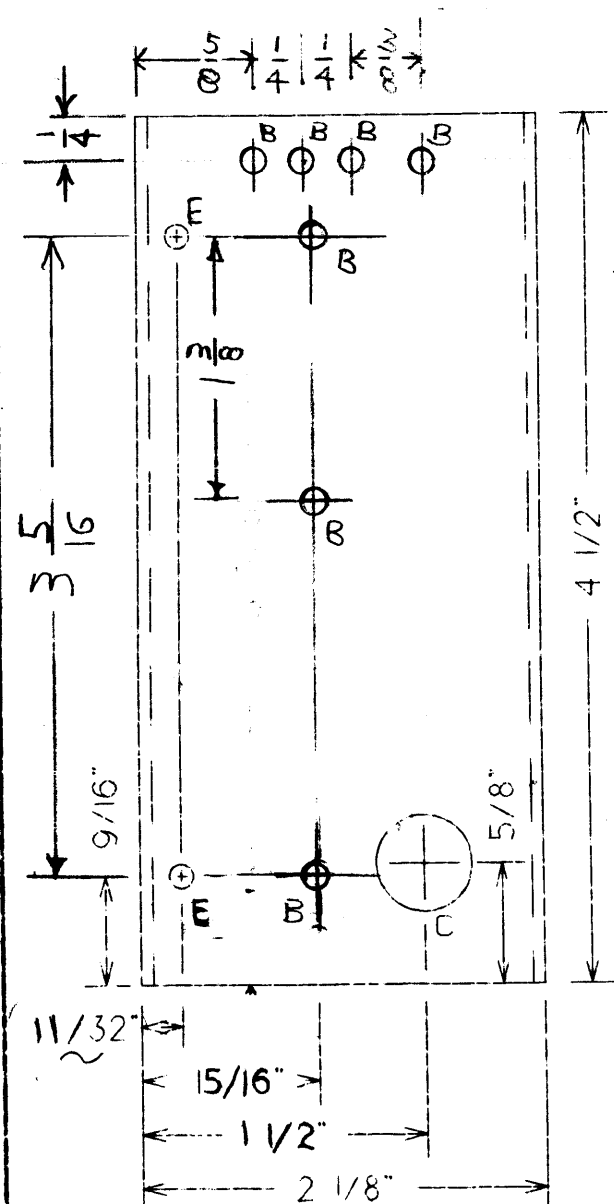

NOTES:
 1. USE MATERIAL THICKNESS FOR MAXIMUM RADIUS ON ALL BENDS
 2. ALL ANGULAR BENDS 90-DEGREES
 3. REMOVE ALL BURRS AND SHARP EDGES
 4. DO NOT INSERTS AFTER FINISHING

THE TECHNICAL MATERIEL CORPORATION MAMARONECK, NEW YORK 10543			
DATE 14 SEP 1992	DRAWN BY N dePASQUALE	APPROVED BY F BUDETTI	
SCALE 1.0 : 1.0			
CHASSIS, MAIN			
USED ON AZ102	SPECIFICATION .064 ALUMINUM 5052-H32	DRAWING MS3919	REV 0